



# PAM8602E

## Filterless 2W Class-D Stereo Audio Amplifier with DC Volume Control and Headphone Output

### Key Features

- 2.0W Output with a 4Ω Load and 5V Power Supply
- Filterless, Low Quiescent Current and Low EMI
- Low THD+N
- 64-step DC Volume Control
- Headphone Output Function
- Superior Low Noise
- Low pop noise
- Efficiency up to 88%
- Short Circuit Protection
- Thermal Shutdown
- Few External Components to Save the Space and Cost
- Pb-Free Package

### General Description

The PAM8602E is a 2.0W, class-D audio amplifier with headphone amplifier. Advanced 64-step DC volume control minimizes external components and allows speaker volume control and headphone volume control. It offers low THD+N, to produce high-quality sound reproduction. The new filterless architecture allows the device to drive the speaker directly, without low-pass output filters, which will save 30% system cost and 75% PCB area.

With the same numbers of external components, the efficiency of the PAM8602E is much better than class-AB cousins. It can extend the battery life thus be ideal for portable applications.

The PAM8602E is available in a SSOP-24 and SOP-24 package.

### Applications

- LCD Monitors / TV Projectors
- Notebook Computers
- Portable Speakers
- Portable DVD Players, Game Machines
- VoIP/Speaker Phones

### Typical Application

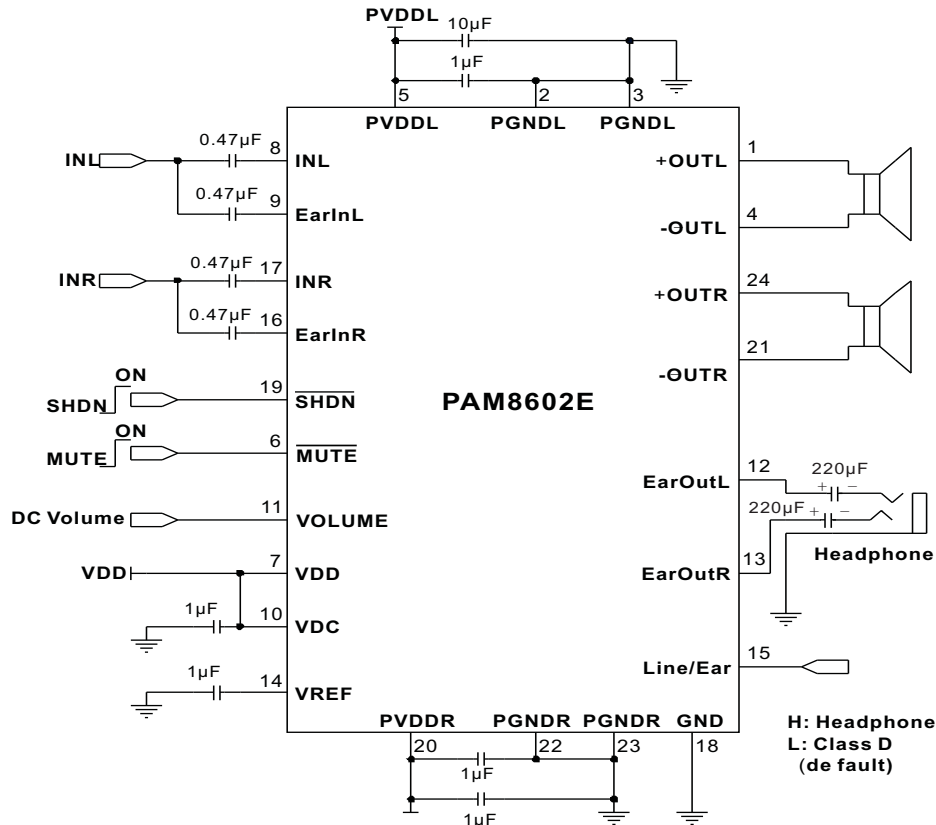



# PAM8602E

Filterless 2W Class-D Stereo Audio Amplifier with DC Volume Control and Headphone Output

## Block Diagram

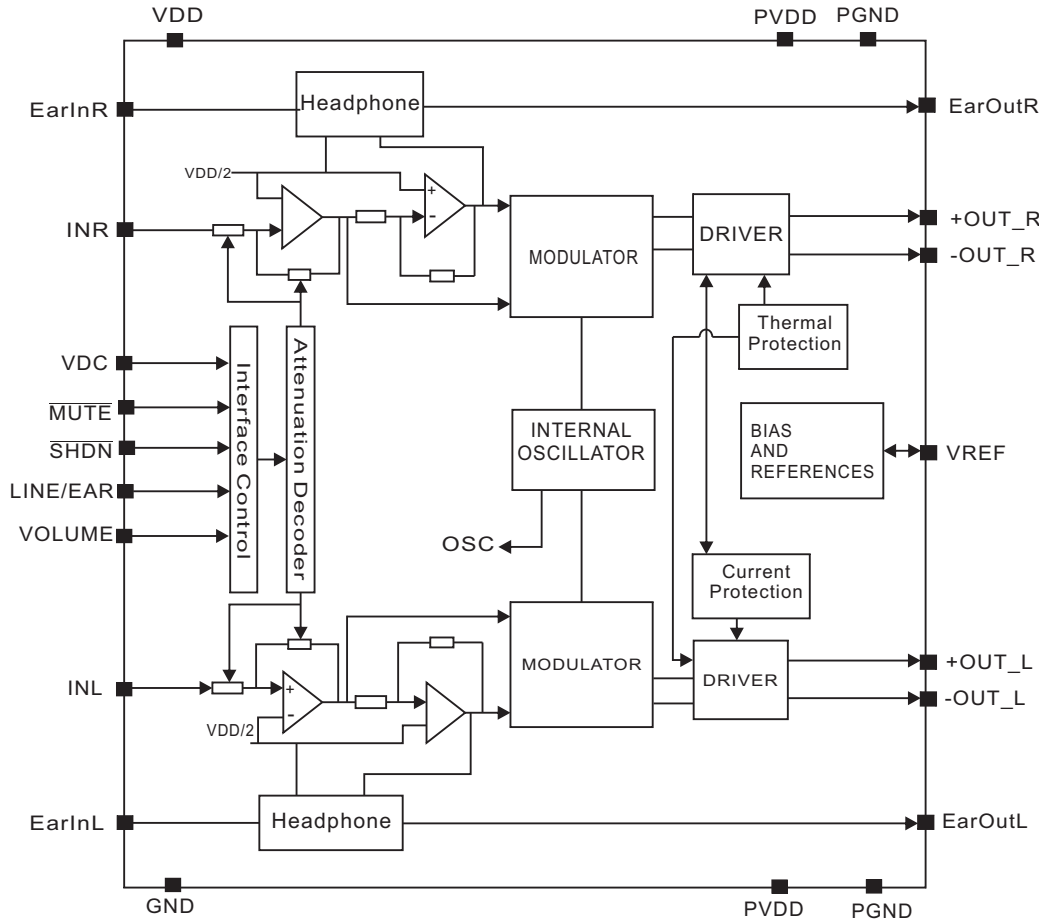

## Pin Configuration & Marking Information

SSOP24  
Top View

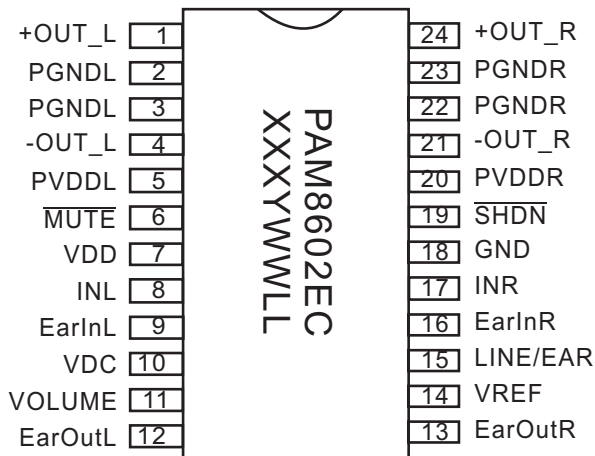

SOP24  
Top View

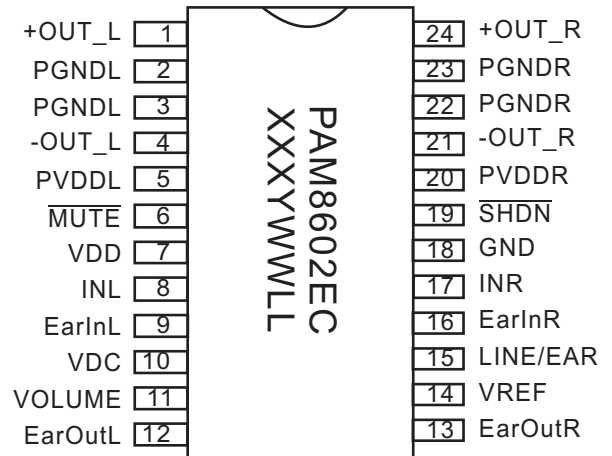

X: Internal Code  
Y: Year  
WW: Week  
LL: Internal Code

Power Analog Microelectronics, Inc



# PAM8602E

Filterless 2W Class-D Stereo Audio Amplifier  
with DC Volume Control and Headphone Output

## Pin Descriptions

Pin Number	Pin Name	Description
1	+OUT_L	Left Channel Positive Output
2	PGNDL	Left Channel Power GND
3	PGNDL	Left Channel Power GND
4	-OUT_L	Left Channel Negative Output
5	PVDDL	Left Channel Power Supply
6	$\overline{\text{MUTE}}$	Mute Control Input (active low)
7	VDD	Analog VDD
8	INL	Left Channel Input
9	EarInL	Left Earphone input
10	VDC	Analog reference for gain control section
11	VOLUME	DC volume control to set the gain of Class-D
12	EarOutL	Left Earphone output
13	EarOutR	Right Earphone output
14	VREF	Internal analog reference, connect a bypass capacitor from VREF to GND
15	LINE/EAR	Line / earphone detect
16	EarInR	Right Earphone input
17	INR	Right Channel Input
18	GND	Analog GND
19	$\overline{\text{SHDN}}$	Shutdown Control Input(active low)
20	PVDDR	Right Channel Power Supply
21	-OUT_R	Right Channel Negative Output
22	PGNDR	Right Channel Power GND
23	PGNDR	Right Channel Power GND
24	+OUT_R	Right Channel Positive Output

## Absolute Maximum Ratings

These are stress ratings only and functional operation is not implied. Exposure to absolute maximum ratings for prolonged time periods may affect device reliability. All voltages are with respect to ground.

Supply Voltage .....	6.0V	Operation Junction Temperature ....	-40°C to 125°C
Input Voltage.....	-0.3V to $V_{DD}+0.3V$	Storage Temperature.....	-65°C to 150°C
		Soldering Temperature.....	300°C,5sec

## Recommended Operating Conditions

Supply Voltage Range.....	2.5V to 5.5V	Ambient Operation Temperature	
Junction Temperature Rang.....	-20°C to 125°C	Range.....	-20°C to 85°C

## Thermal Information

Parameter	Symbol	Package	Maximum	Unit
Thermal Resistance (Junction to Ambient)	$\theta_{JA}$	SSOP-24	96	°C/W
Thermal Resistance (Junction to Ambient)	$\theta_{JA}$	SOP-24	79.2	°C/W

Power Analog Microelectronics, Inc



# PAM8602E

## Filterless 2W Class-D Stereo Audio Amplifier with DC Volume Control and Headphone Output

### Electrical Characteristic

$V_{DD}=5V$ , Gain = Maximum,  $R_L=8\Omega$ ,  $T_A=25^\circ C$ , unless otherwise noted.

PARAMETER	SYMBOL	CONDITIONS	MIN	TYP	MAX	UNITS
<b>Class D Stage</b>						
Supply Voltage Range	$V_{DD}$		2.5		5.5	V
Quiescent Current	$I_Q$	No Load		10	15	mA
Output Offset Voltage	$V_{OS}$	No Load		10	30	mV
Drain-Source On-State Resistance	$R_{DS(ON)}$	$I_{DS}=0.5A$	P MOSFET	0.35		$\Omega$
			N MOSFET	0.25		
Output Power	$P_O$	THD+N=10%,f=1kHz	1.55	1.7		W
Total Harmonic Distortion Plus Noise	THD+N	$P_O=0.85W$ ,f=1KHz		0.08		%
Power Supply Ripple Rejection	PSRR	Input AC-GND, f=1KHz, $V_{pp}=200mV$		70		dB
Channel Separation	CS	$P_O=1W$ , f=1KHz		-95		dB
Oscillator Frequency	$f_{OSC}$		200	250	300	kHz
Efficiency	$\eta$	$P_O=1.7W$ ,f=1kHz	85	89		%
Noise	$V_n$	Input AC-GND	A-weighting	220		$\mu V$
			No A-weighting	350		
Signal Noise Ratio	SNR	f=20-20kHz, THD=1%		85		dB
<b>Earphone Stage</b>						
Quiescent Current	$I_Q$	No Load		4.5	7.5	mA
Output Offset Voltage	$V_{OS}$	No Load		2.5		V
Output Power	$P_O$	THD+N=1%, $R_L=32\Omega$ , f=1KHz		60		mW
Total Harmonic Distortion Plus Noise	THD+N	$R_L = 32\Omega$ , $P_O=10mW$ ,f=1KHz		0.02		%
Power Supply Ripple Rejection	PSRR	Input AC-GND, f=1KHz, $V_{pp}=200mV$		75		dB
Channel Separation	CS	$P_O=1W$ , f=1KHz		-85		dB
Noise	$V_n$	Input AC-GND	A-weighting	70		$\mu V$
			No A-weighting	40		
Signal Noise Ratio	SNR	f=20-20kHz, THD=1%		75		dB
<b>Control Section</b>						
Under Voltage Lock-out	UVLO			2		V
Mute Current	$I_{MUTE}$	$V_{MUTE}=0V$		1	3	mA
Shutdown Current	$I_{SHDN}$	$V_{SHDN}=0V$			1	$\mu A$
$\overline{SHDN}$ Input High	$V_{SH}$		1.2			V
$\overline{SHDN}$ Input Low	$V_{SL}$				0.5	
$\overline{MUTE}$ Input High	$V_{MH}$		1.2			V
$\overline{MUTE}$ Input Low	$V_{ML}$				0.5	
Over Temperature Protection	OTP			140		$^\circ C$
Over Temperature Hysteresis	OTH			30		$^\circ C$



# PAM8602E

Filterless 2W Class-D Stereo Audio Amplifier  
with DC Volume Control and Headphone Output

## Typical Operating Characteristics ( $T_A=25^\circ\text{C}$ )

### Class D Output

1. THD+N vs Output Power

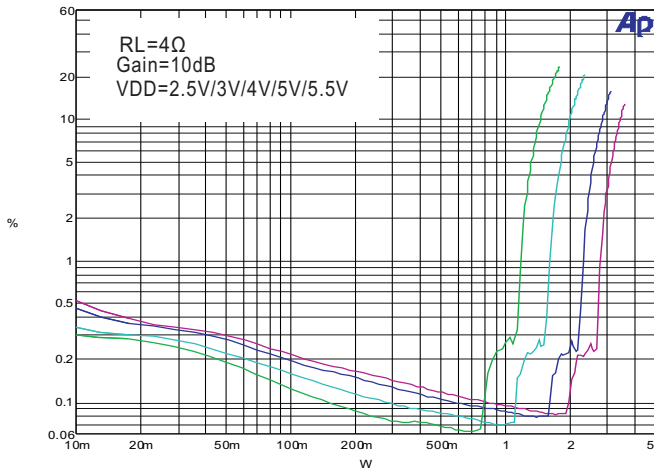

2. THD+N vs Output Power

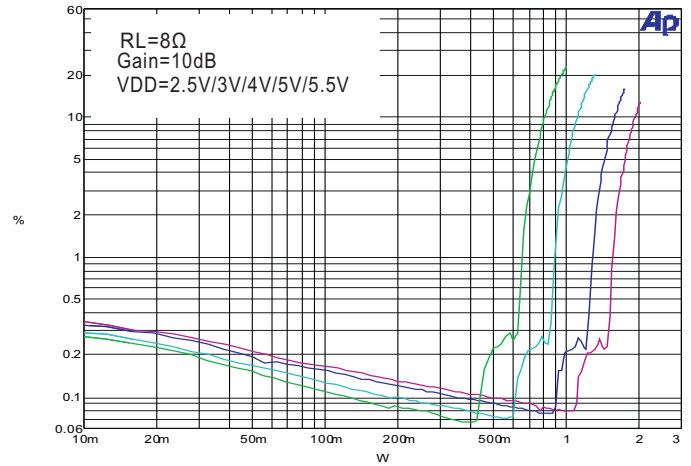

3. THD+N vs Frequency

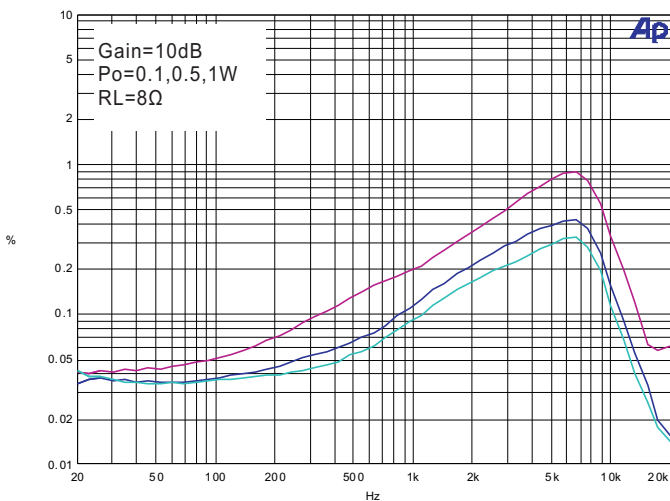

4. Crosstalk vs Frequency

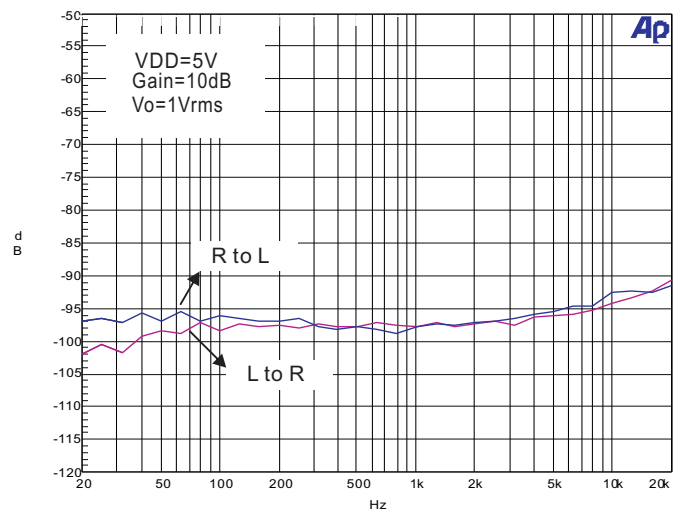

5. Frequency Response

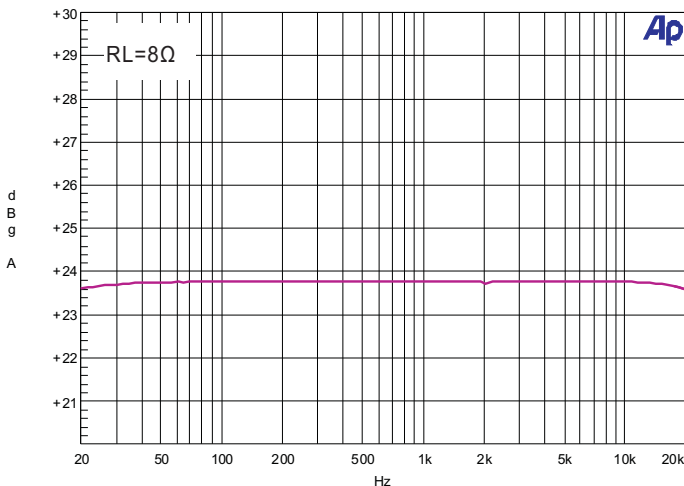

6. Noise Floor

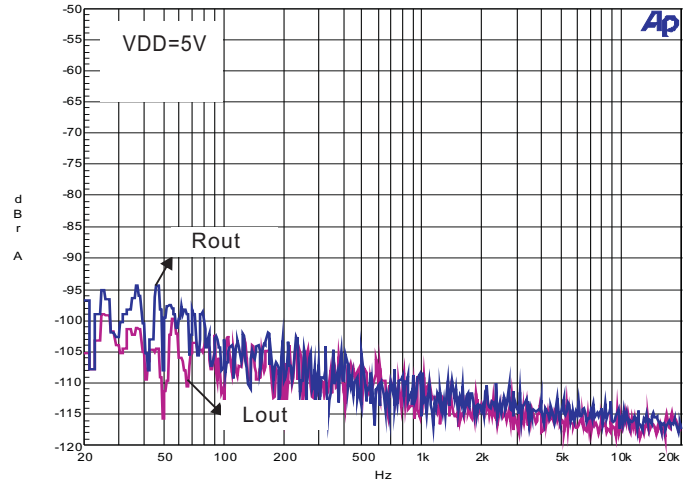



# PAM8602E

Filterless 2W Class-D Stereo Audio Amplifier with DC Volume Control and Headphone Output

## Typical Operating Characteristics (continued)

### Class D Output

7. Power Dissipation vs Output Power

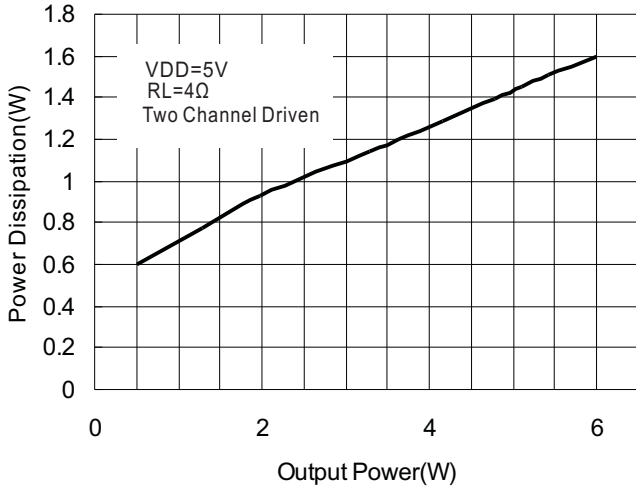

8. Power Dissipation vs Output Power

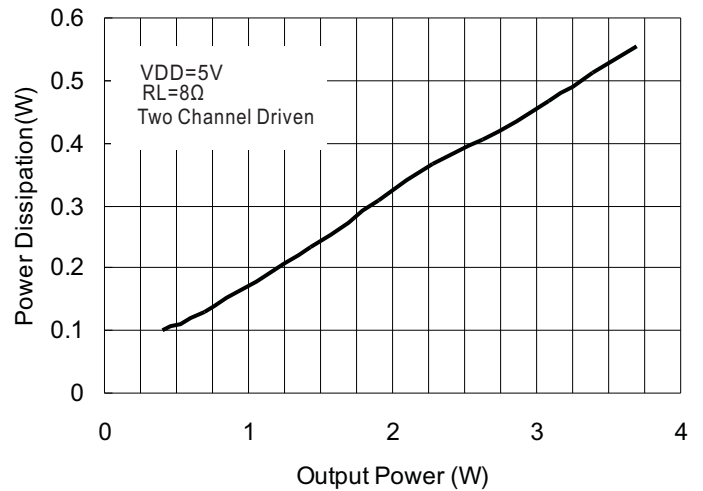

9. Case Temperature vs Output Power

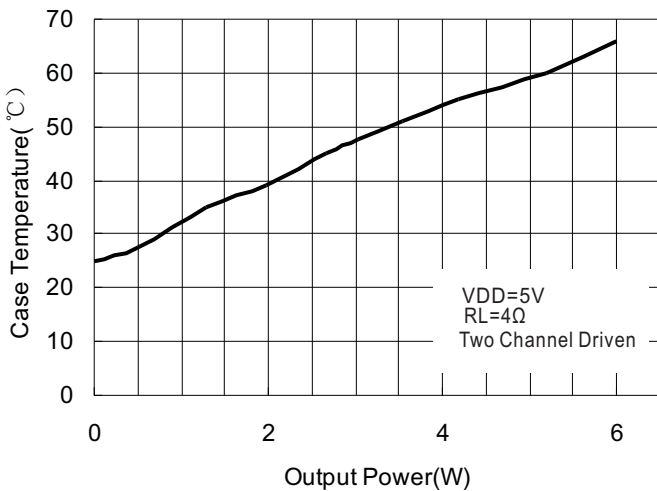

10. Case Temperature vs Output Power

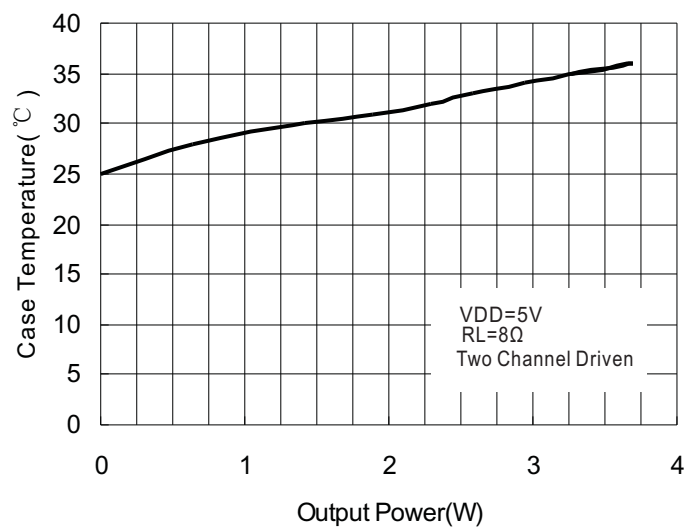

11. PSRR vs Frequency

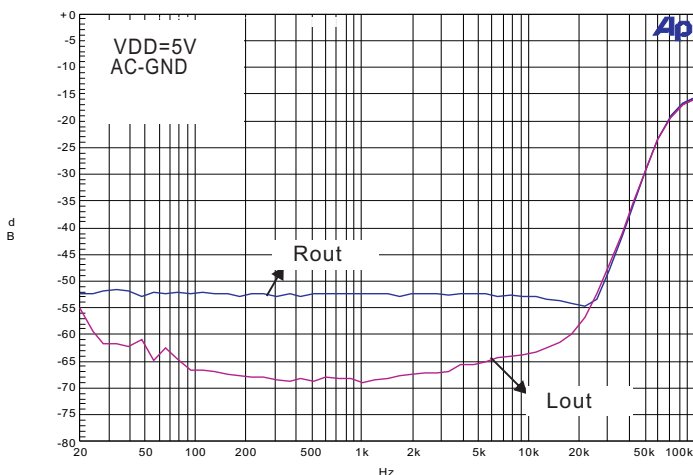



# PAM8602E

Filterless 2W Class-D Stereo Audio Amplifier  
with DC Volume Control and Headphone Output

## Typical Operating Characteristics (continued)

### Earphone Output

12. THD+N vs Output Power

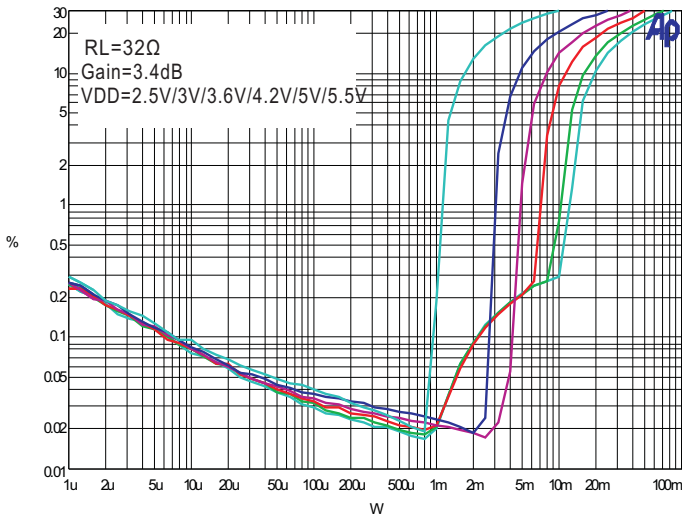

13. THD+N vs Frequency

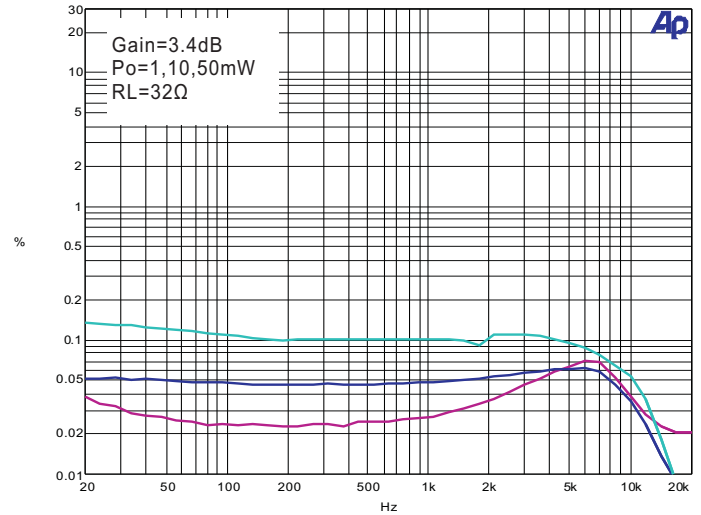

14. Crosstalk vs Frequency

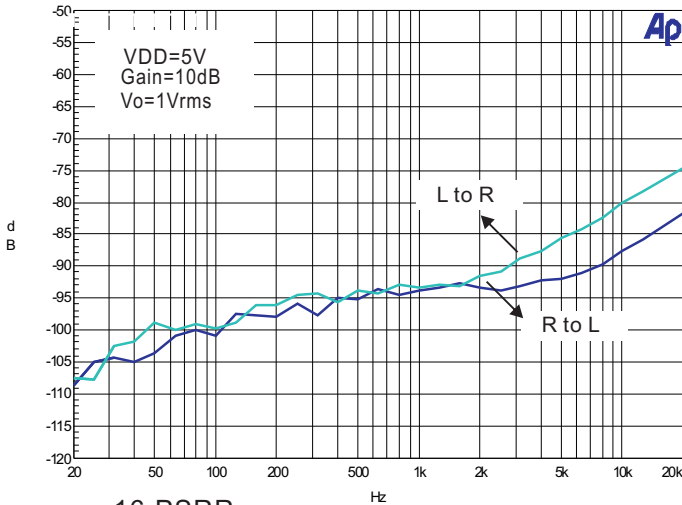

15. Frequency Response

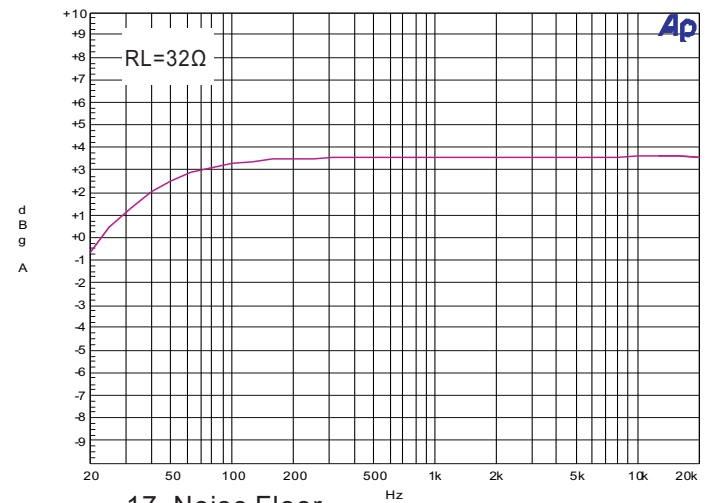

16. PSRR

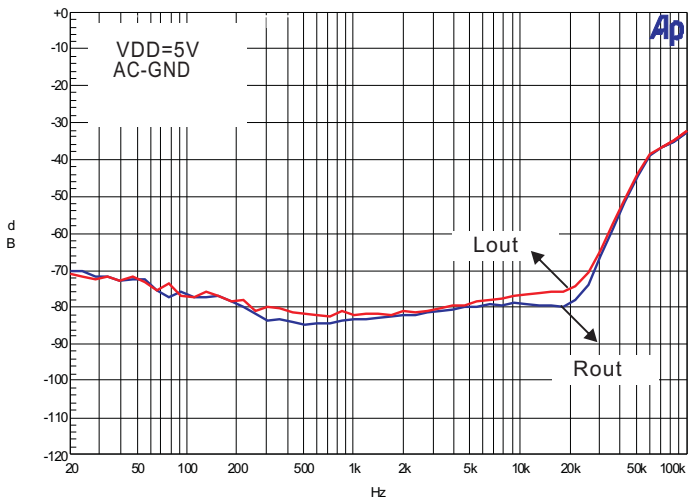

17. Noise Floor

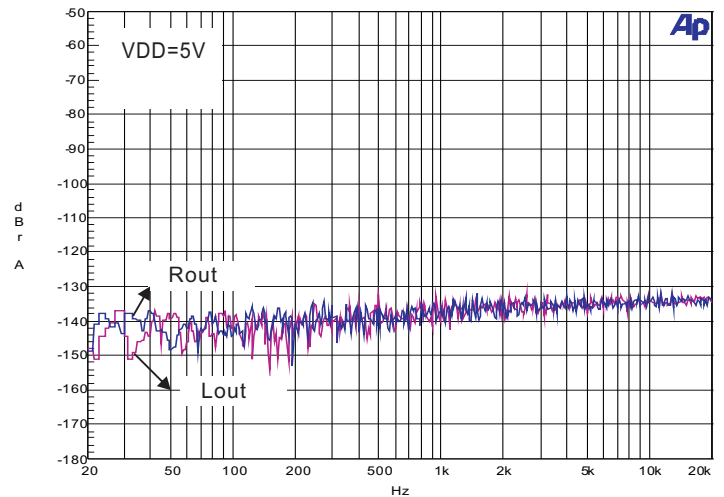



# PAM8602E

Filterless 2W Class-D Stereo Audio Amplifier  
with DC Volume Control and Headphone Output

## Typical Operating Characteristics (continued)

19. Efficiency VS Output Power

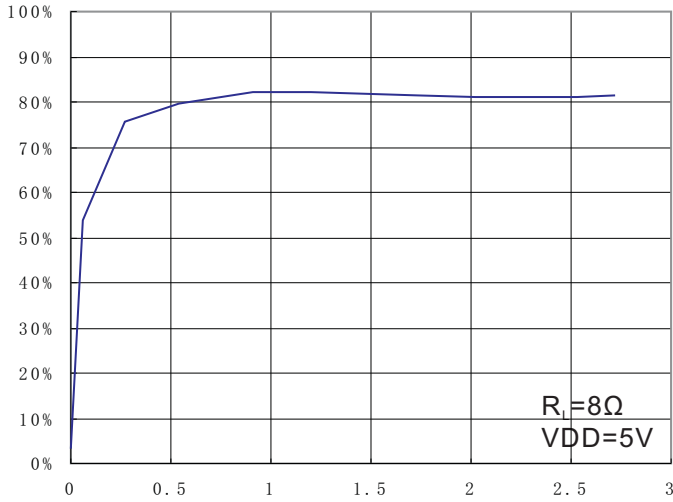

20. Efficiency VS Output Power

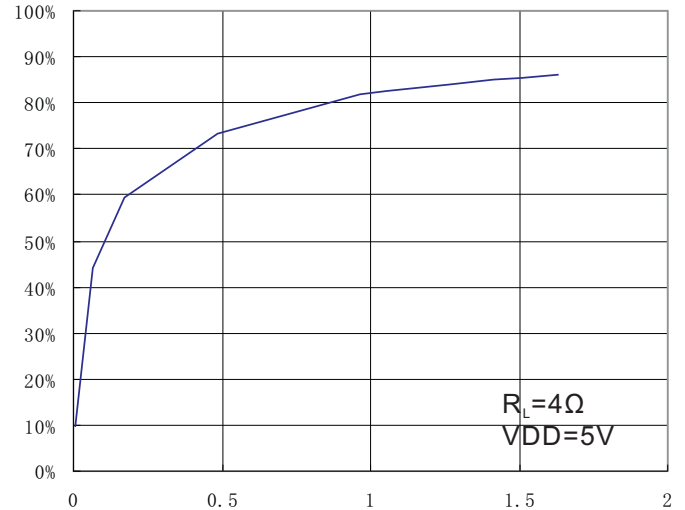

21. Rdson VS Input Voltage

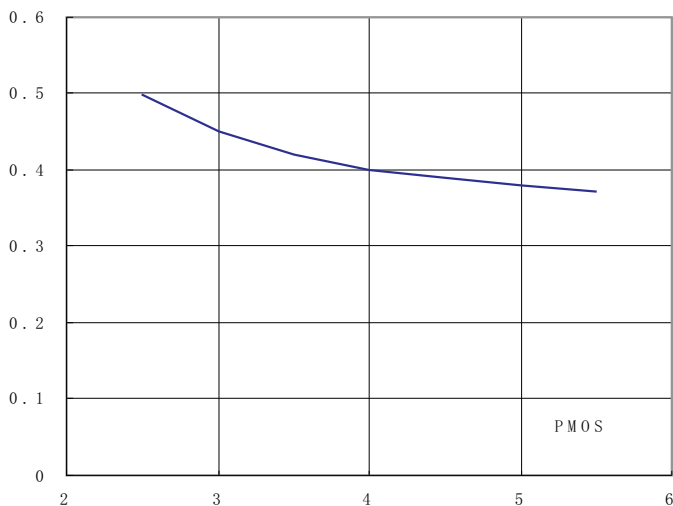

22. Rdson VS Input Voltage

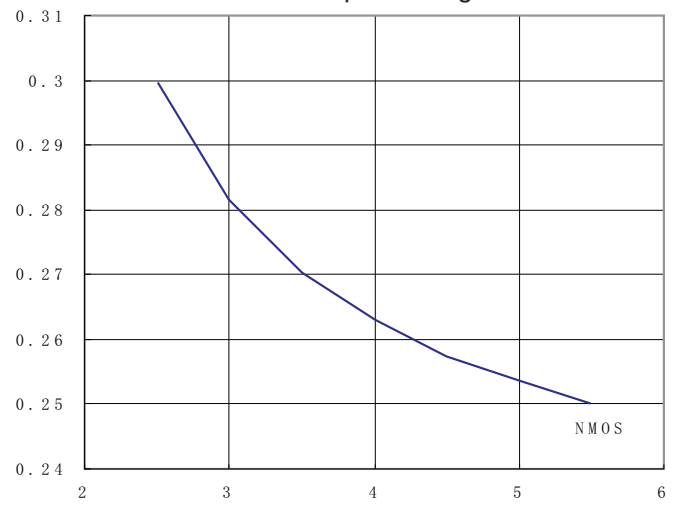

23. Quiescent Current VS VDD(Class D)

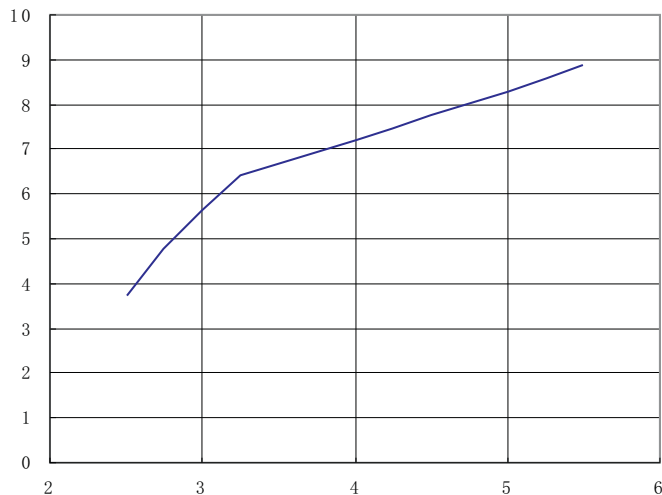

24. Quiescent Current VS VDD(Earphone)

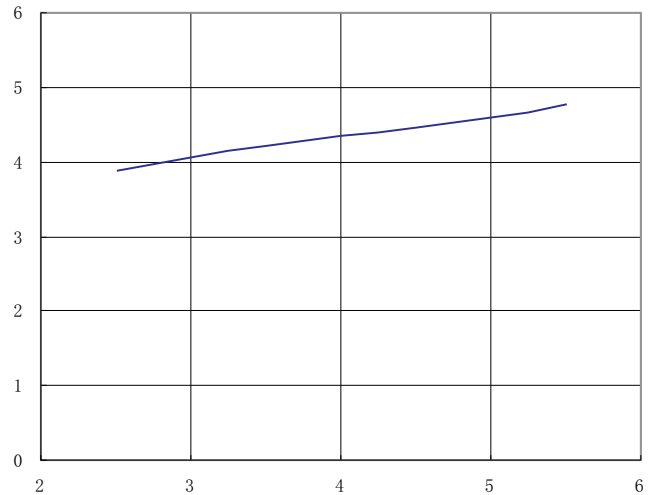



# PAM8602E

Filterless 2W Class-D Stereo Audio Amplifier  
with DC Volume Control and Headphone Output

## Typical Operating Characteristics (continued)

27. Shutdown Current

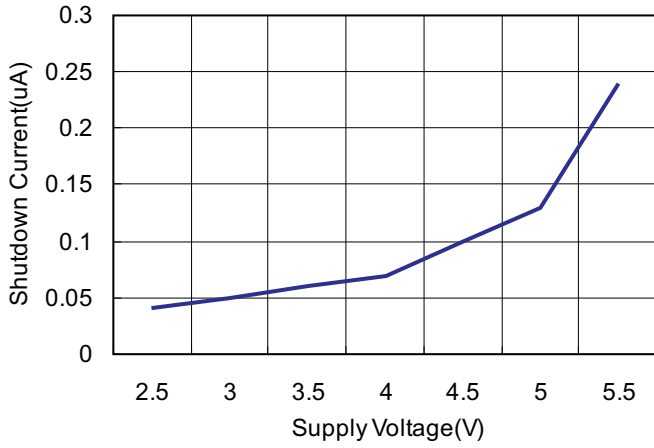

28. Switching Frequency (Class D)

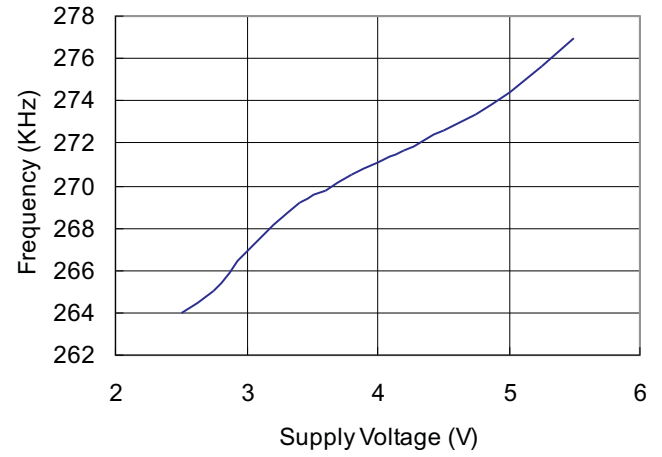

29. Gain Control (Class D)

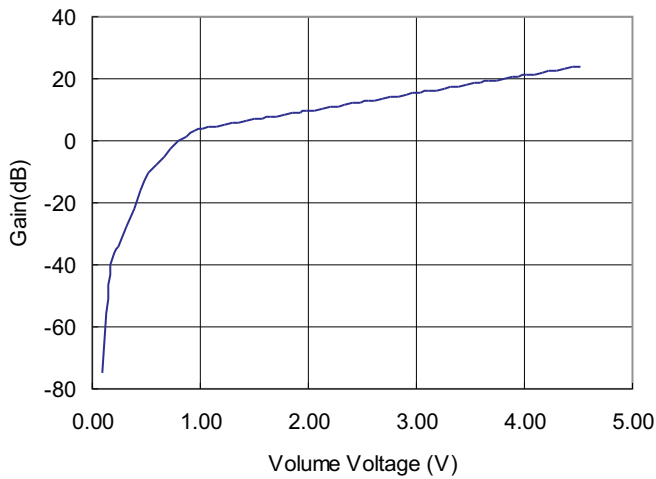

30. Gain Control (Earphone)

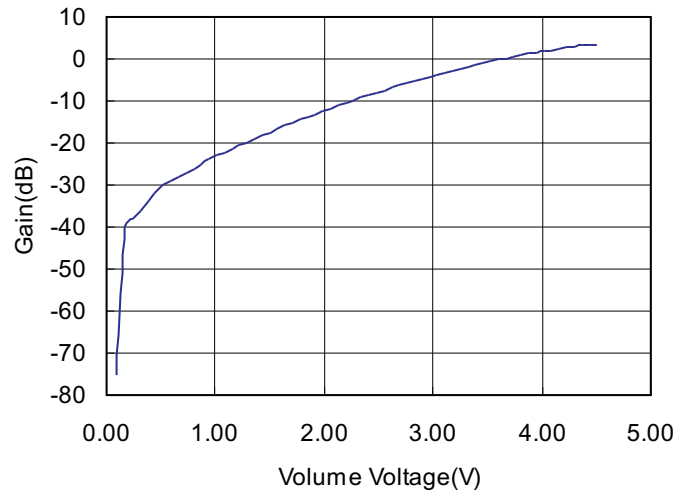



# PAM8602E

Filterless 2W Class-D Stereo Audio Amplifier  
with DC Volume Control and Headphone Output

## Typical Operating Characteristics (continued)

Table 1. DC Volume Control

STEP	Gain(dB) Class D	Gain(dB) Earphone	STEP	Gain(dB) Class D	Gain(dB) Earphone
0	-75	-75	32	11.6	-9.2
1	-40	-40	33	12	-8.6
2	-34	-38	34	12.4	8
3	-28	-36	35	12.8	-7.4
4	-22	-34	36	13.2	-6.8
5	-16	-32	37	13.6	-6.2
6	-10	-30	38	14	-5.7
7	-7.5	-29	39	14.4	-5.2
8	-5	-28	40	14.8	-4.7
9	-2.5	-27	41	15.2	-4.2
10	0	-26	42	15.6	-3.7
11	1.5	-25	43	16	-3.2
12	3	-24	44	16.4	-2.7
13	4	-23	45	16.8	-2.2
14	4.4	-22.2	46	17.2	-1.8
15	4.8	-21.4	47	17.6	-1.4
16	5.2	-20.6	48	18	-1
17	5.6	-19.8	49	18.4	-0.6
18	6	-19	50	18.8	-0.2
19	6.4	-18.2	51	19.2	0.2
20	6.8	-17.4	52	19.6	0.6
21	7.2	-16.6	53	20	0.9
22	7.6	-15.9	54	20.4	1.2
23	8	-15.2	55	20.8	1.5
24	8.4	-14.5	56	21.2	1.8
25	8.8	-13.8	57	21.6	2.1
26	9.2	-13.1	58	22	2.4
27	9.6	-12.4	59	22.4	2.7
28	10	-11.7	60	22.8	2.9
29	10.4	-11	61	23.2	3.1
30	10.8	-10.4	62	23.6	3.3
31	11.2	-9.8	63	24	3.5

### Test Setup for Performance Testing(Class D)

#### Application Notice

1. When the PAM8602E works with LC filters, it should be connected with the speaker before it's powered on, otherwise it will be damaged easily.
2. When the PAM8602E works without LC filters, it's better to add a ferrite chip bead at the outgoing line of speaker for suppressing the possible electromagnetic interference.
3. The absolute maximum rating of the PAM8602E operation voltage is 6.0V. When the PAM8602E is powered with 4 battery cells, it should be noted that the voltage of 4 new dry or alkaline batteries is over 6V, higher than its maximum operation voltage, which probably

make the device damaged. Therefore, it's recommended to use either 4 Ni-MH (Nickel Metal Hydride) rechargeable batteries or 3 dry or alkaline batteries.

4. The input signal should not be too high, if too high, it will cause the clipping of output signal when increasing the volume. Because the DC volume control of the PAM8602E has big gain, it will make the device damaged.

5. When testing the PAM8602E without LC filters by using resistor instead of speaker as the output load, the test results, e.g. THD or efficiency, will be worse than those using speaker as load.

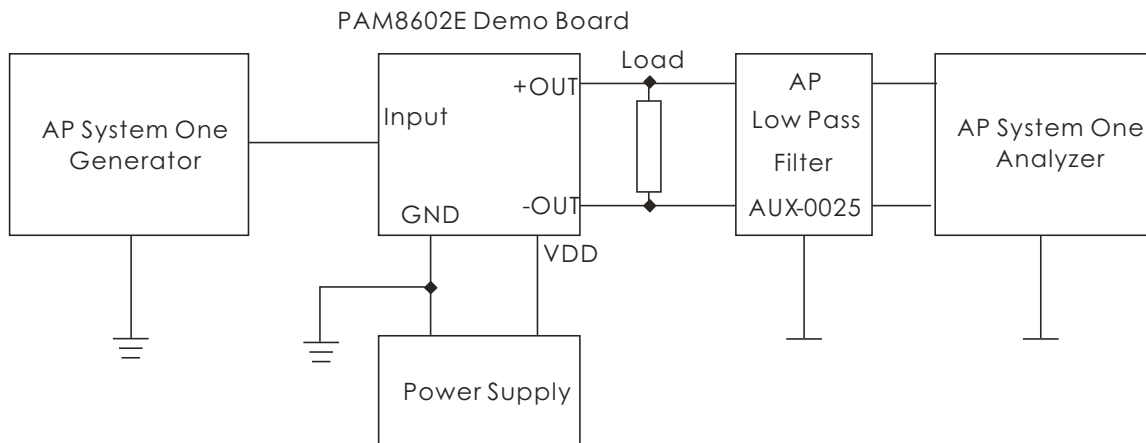

#### Notes

1. The AP AUX-0025 low pass filter is necessary for class-D amplifier measurement with AP analyzer.
2. Two 22 $\mu$ H inductors are used in series with load resistor to emulate the small speaker for efficiency measurement.



### Application Information (continued)

#### Mute Operation

The  $\overline{\text{MUTE}}$  pin is an input for controlling the output state of the PAM8602E. A logic low on this pin disables the outputs, and a logic high on this pin enables the outputs. This pin may be used as a quick disable or enable of the outputs without a volume fade. Quiescent current is listed in the electrical characteristic table. The  $\overline{\text{MUTE}}$  pin can be left floating due to the internal pull-up.

#### Shutdown operation

In order to reduce power consumption while not in use, the PAM8602E contains shutdown circuitry to turn off the amplifier's bias circuitry. The amplifier is turned off when logic low is placed on the  $\overline{\text{SHDN}}$  pin. By switching the  $\overline{\text{SHDN}}$  pin connected to GND, the PAM8602E supply current draw will be minimized in idle mode. The  $\overline{\text{SHDN}}$  pin can be left floating due to the internal pull-up.

**For the best power on/off pop performance, the amplifier should be placed in the Mute mode prior to turning on/off the power supply.**

#### Power supply decoupling

The PAM8602E is a high performance CMOS audio amplifier that requires adequate power supply decoupling to ensure the output THD and PSRR are as low as possible. Power supply decoupling affects low frequency on the power supply leads. For higher frequency response. Optimum decoupling is achieved by using two capacitors of different types that target different types of noise frequency transients, spikes, or digital hash on the line, a good low equivalent-series-resistance (ESR) ceramic capacitor, typically  $1.0\mu\text{F}$ , placed as close as possible to the device  $V_{\text{DD}}$  terminal works best. For filtering lower-frequency noise signals, a large capacitor of  $10\mu\text{F}$  (ceramic) or greater placed near the audio power amplifier is recommended.

#### Input Capacitor ( $C_i$ )

Large input capacitors are both expensive and space hungry for portable designs. Clearly, a certain sized capacitor is needed to couple in low frequencies without severe attenuation. But in many cases the speakers used in portable systems, whether internal or external, have little ability to reproduce signals below 100Hz to 150Hz. Thus, using a large input capacitor may not increase actual system performance. In this case, input capacitor ( $C_i$ ) and input resistance ( $R_i$ )

of the amplifier form a high-pass filter with the corner frequency determined equation below,

In addition to system cost and size, click and pop performance is affected by the size of the input coupling capacitor,  $C_i$ . A larger input coupling capacitor requires more charge to reach its quiescent DC voltage (nominally  $1/2 V_{\text{DD}}$ ). This charge comes from the internal circuit via the feedback and is apt to create pops upon device enable. Thus, by minimizing the capacitor size based on necessary low frequency response, turn-on pops can be minimized.

#### Analog Reference Bypass Capacitor ( $C_{\text{BYP}}$ )

The Analog Reference Bypass Capacitor ( $C_{\text{BYP}}$ ) is the most critical capacitor and serves several important functions. During start-up or recovery from shutdown mode,  $C_{\text{BYP}}$  determines the rate at which the amplifier starts up. The second function is to reduce noise produced by the power supply caused by coupling into the output drive signal. This noise is from the internal analog reference to the amplifier, which appears as degraded PSRR and THD+N.

A ceramic bypass capacitor ( $C_{\text{BYP}}$ ) of  $0.47\mu\text{F}$  to  $1.0\mu\text{F}$  is recommended for the best THD and noise performance. Increasing the bypass capacitor reduces clicking and popping noise from power on/off and entering and leaving shutdown.

#### Under Voltage Lock-out (UVLO)

The PAM8602E incorporates circuitry designed to detect when the supply voltage is low. When the supply voltage drops to 1.8V or below, the PAM8602E outputs are disable, and the device comes out of this state and starts to normal functional once  $V_{\text{DD}} \geq 2.0\text{V}$ .

#### Short Circuit Protection (SCP)

The PAM8602E has short circuit protection circuitry on the outputs that prevents the device from damage when output-to-output and output-to-GND short. When a short circuit is detected on the outputs, the outputs are disable immediately. If the short was removed, the device activates again.

### Application Information (continued)

#### Over Temperature Protection

Thermal protection on the PAM8602E prevents the device from damage when the internal die temperature exceeds 135°C. There is a 15 degree tolerance on this trip point from device to device. Once the die temperature exceeds the thermal set point, the device outputs are disabled. This is not a latched fault. The thermal fault is cleared once the temperature of the die is reduced by 30°C. This large hysteresis will prevent motor boating sound well. The device begins normal operation at this point without external system interaction.

#### How to Reduce EMI (Electro Magnetic Interference)

A simple solution is to put an additional capacitor 1000uF at power supply terminal for power line coupling if the traces from amplifier to speakers are short (<20CM).

Most applications require a ferrite bead filter as shown at Figure 1. The ferrite filter reduces EMI around 1 MHz and higher. When selecting a ferrite bead, choose one with high impedance at high frequencies, and low impedance at low frequencies (MH2012HM221-T).

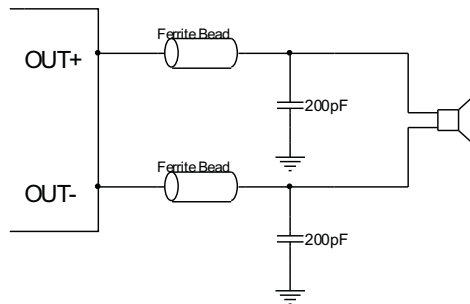

Figure 1: Ferrite Bead Filter to reduce EMI

#### PCB Layout Guidelines Grounding

At this stage it is paramount to notice the necessity of separate grounds. Noise currents in the output power stage need to be returned to output noise ground and nowhere else. Were these currents to circulate elsewhere, they may get into the power supply, the signal ground, etc, worse yet, they may form a loop and radiate noise. Any of these cases results in degraded amplifier performance. The logical returns for the output noise currents associated with Class D switching are the respective PGND pins for each channel. The switch state diagram illustrates that PGND is instrumental in nearly every switch state. This is the perfect point to which the output noise ground trace should return. Also note that output noise ground is channel specific. A two channel amplifier has two separate channels and consequently must have two separate output noise ground traces. The layout of the PAM8602E offers separate PGND connections for each channel and in some cases each side of the bridge. Output noise grounds must be tied to system ground at the power in exclusively. Signal currents for the inputs, reference, etc need to be returned to quiet ground. This ground is only tied to the signal components and the GND pin, and GND then tied to system ground.



# PAM8602E

Filterless 2W Class-D Stereo Audio Amplifier  
with DC Volume Control and Headphone Output

## Ordering Information

PAM8602E X X X

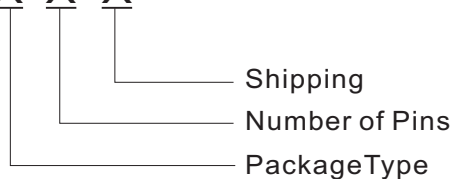

Part Number	Package Type	Standard Package
PAM8602ENHR-C	SSOP-24	2,500 Units/Tape & Reel
PAM8602EDHR-C	SOP-24	1,000 Units/Tape & Reel

### Outline Dimension

#### SSOP-24

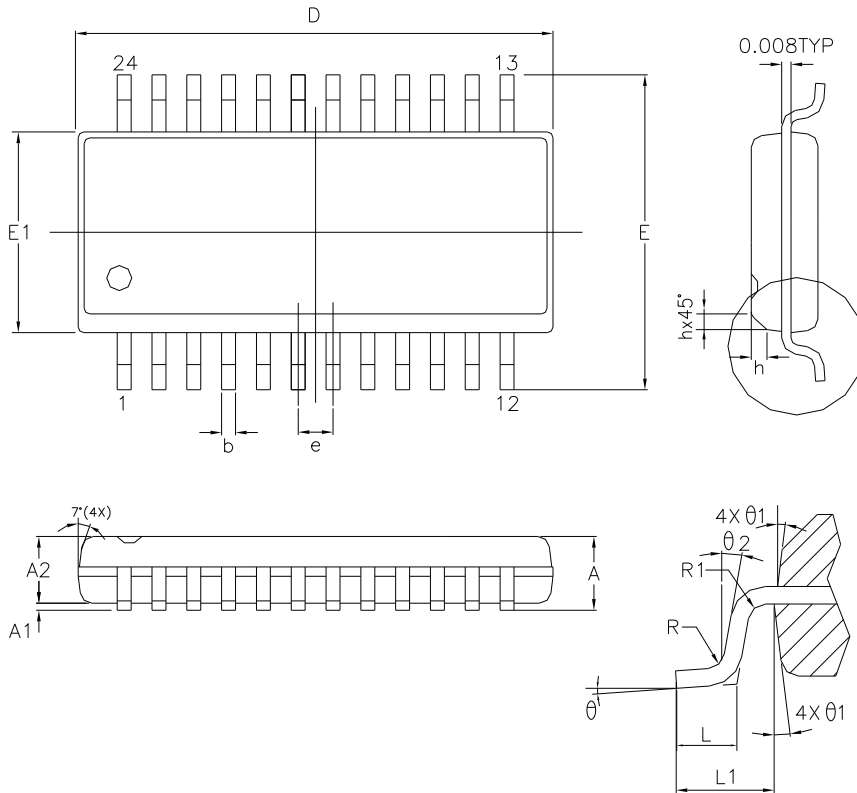

SYMBOLS	MIN.	NOM.	MAX.
A	0.053	0.061	0.069
A1	0.004	-	0.010
A2	0.049	0.057	0.065
b	0.008	0.010	0.012
D	0.335	0.341	0.347
E	0.228	0.236	0.244
E1	0.150	0.154	0.158
e	-	0.025	-
L	0.016	0.033	0.050
L1	0.041 REF		
R	0.003	-	-
R1	0.003	-	-
h	0.010	0.015	0.020
θ	0°	4°	8°
θ1	5°	10°	15°
θ2	0°	-	-

UNIT : INCH

### Outline Dimension

#### SOP-24

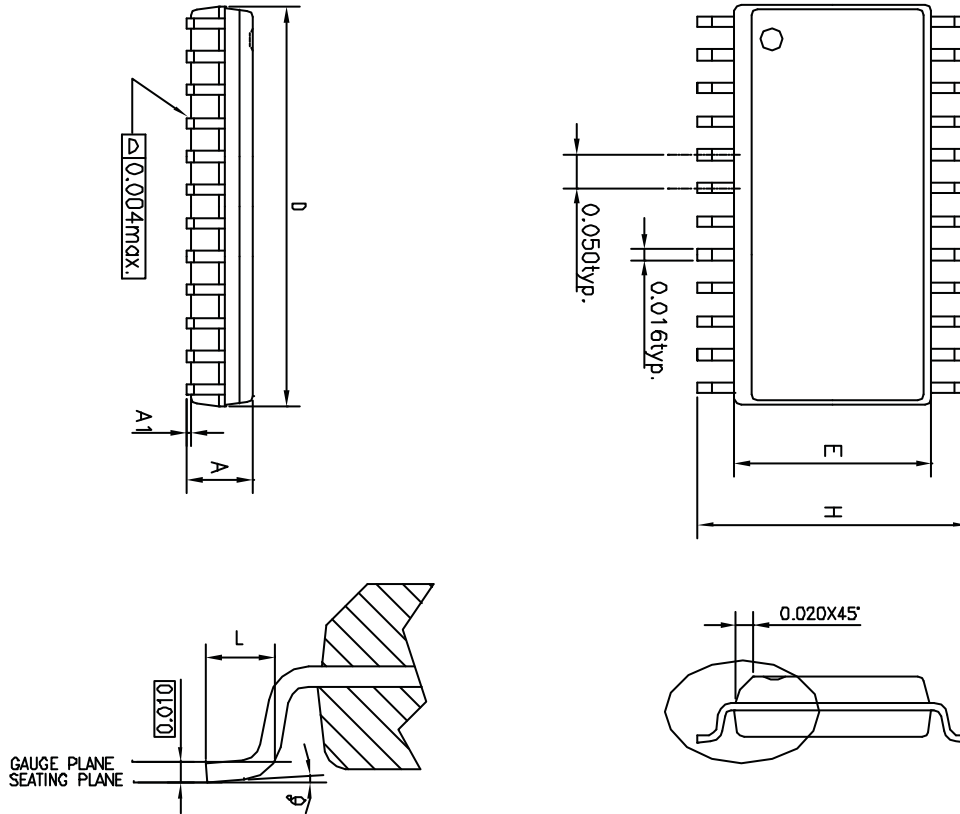

SYMBOLS	MIN.	NOM	MAX.
A	0.093	0.099	0.104
A1	0.004	—	0.012
D	0.599	0.600	0.614
E	0.291	0.295	0.299
H	0.394	0.406	0.419
L	0.016	0.035	0.050
θ°	0	—	8

UNIT : INCH

#### NOTES:

1. JEDEC OUTLINE : MS-013 AD
2. DIMENSIONS "D" DOES NOT INCLUDE MOLD FLASH, PROTRUSIONS OR GATE BURRS. MOLD FLASH, PROTRUSIONS AND GATE BURRS SHALL NOT EXCEED .15mm (.006in) PER SIDE.
3. DIMENSIONS "E" DOES NOT INCLUDE INTER-LEAD FLASH, OR PROTRUSIONS. INTER-LEAD FLASH AND PROTRUSIONS SHALL NOT EXCEED .25mm (.010in) PER SIDE.