



PAM8303C

Ultra Low EMI, 3W Filterless Mono Class-D Audio Power Amplifier

Key Features

- Ultra Low EMI, -20dB Better Than FCC Class-B @ 300MHz
- High Efficiency up to 90% @1W with an 8Ω Speaker
- Shutdown Current <math><1\mu\text{A}</math>
- 3W@10% THD Output with a 4Ω Load at 5V Supply
- Demanding Few External Components
- Superior Low Noise without Input
- Supply Voltage from 2.8V to 5.5 V
- Short Circuit Protection
- Thermal Shutdown
- Available in Space Saving Packages: 1.45mmx1.45mm WCSP9, MSOP-8, DFN 3x3
- Pb-Free Package

General Description

The PAM8303C is a 3W mono filterless class-D amplifier with high PSRR and differential input that eliminate noise and RF rectification.

Features like 90% efficiency and small PCB area make the PAM8303C class-D amplifier ideal for cellular handsets. The filterless architecture requires no external output filter, fewer external components, less PCB area and lower system costs, and simplifies application design.

The PAM8303C features short circuit protection and thermal shutdown.

The PAM8303C is available in 9-ball WCSP, MSOP-8 and DFN 3x3 8-pin packages.

Applications

- Cellular Phones/Smart Phones
- MP4/MP3
- GPS
- Digital Photo Frame
- Electronic Dictionary
- Portable Game Machines

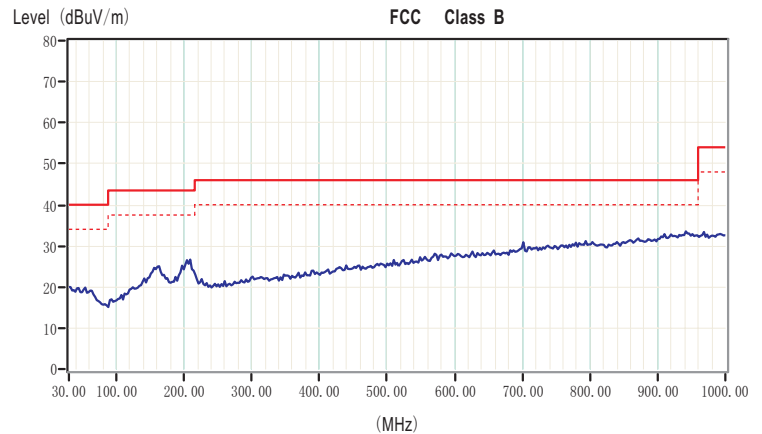

EMI vs Frequency

Typical Application Circuit

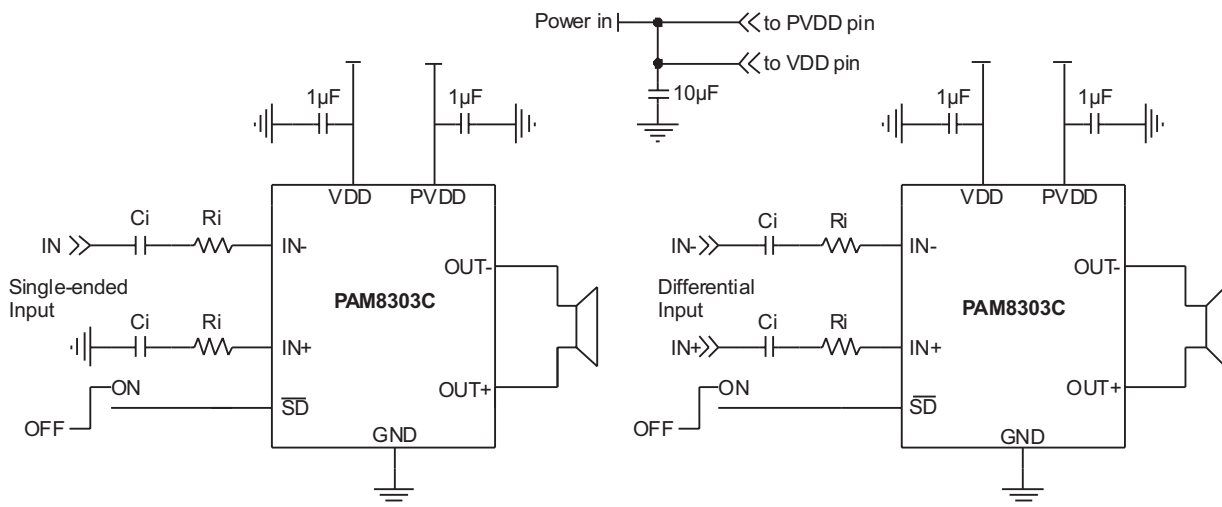

Block Diagram

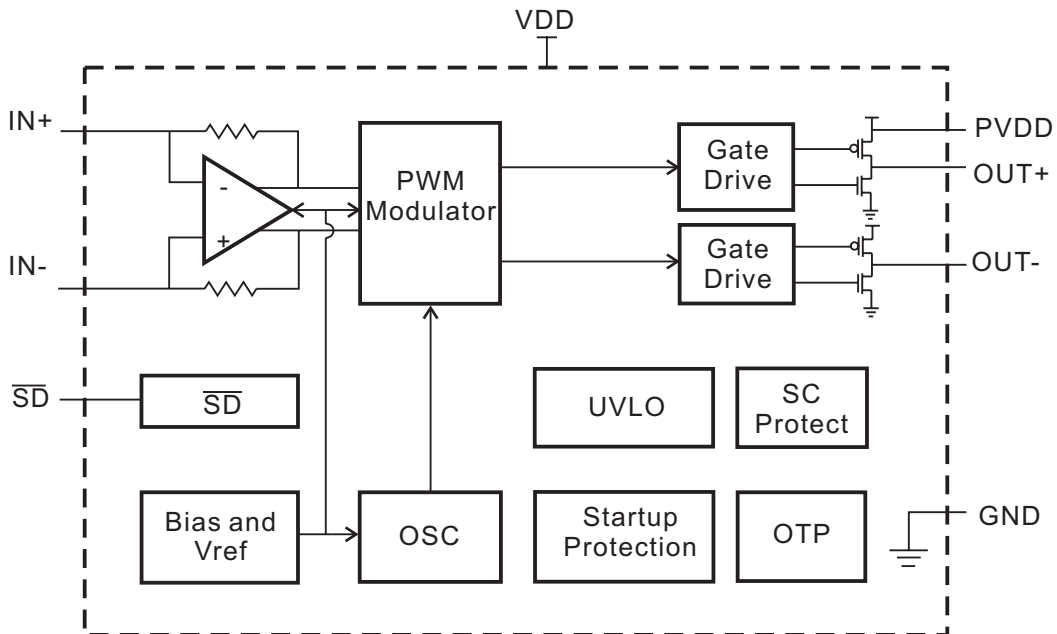

Pin Configuration & Marking Information

9 Ball WCSP(A)
Top View

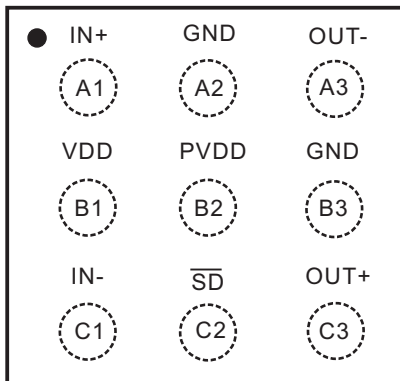

Marking

BH
YW

BH: Product Code of PAM8303C
Y: Year
W: Week

Pin Configuration & Marking Information

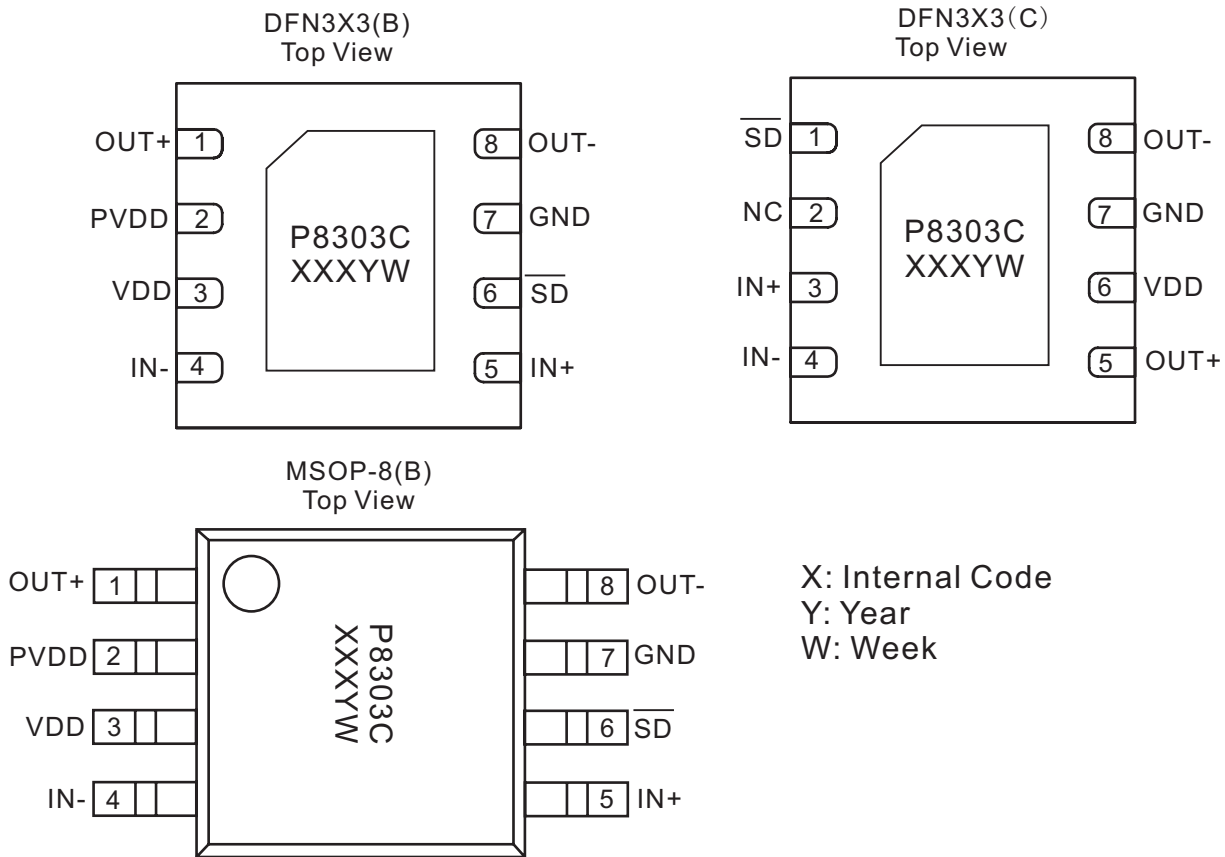

Pin Name	WCSP(A)	DFN3X3 (B)	DFN3X3 (C)	MSOP8 (B)	Description
OUT+	C3	1	5	1	Negative BTL output
PVDD	B2	2	-	2	Power supply
VDD	B1	3	6	3	Analog power supply
IN-	C1	4	4	4	Negative differential input
IN+	A1	5	3	5	Positive differential input
$\overline{\text{SD}}$	C2	6	1	6	Shutdown terminal ,active low
GND	A2,B3	7	7	7	Ground
OUT-	A3	8	8	8	Positive BTL output
NC	-	-	2	-	



PAM8303C

Ultra Low EMI, 3W Filterless Mono Class-D Audio Power Amplifier

Absolute Maximum Ratings

These are stress ratings only and functional operation is not implied. Exposure to absolute maximum ratings for prolonged time periods may affect device reliability. All voltages are with respect to ground.

Supply Voltage.....6.0V	Storage Temperature.....-65°C to 150°C
Input Voltage.....-0.3V to $V_{DD}+0.3V$	Maximum Junction Temperature.....150°C
	Soldering Temperature.....250°C, 10 sec

Recommended Operating Conditions

Supply voltage Range.....2.8V to 5.5V	Ambient Temperature Range.....-40°C to 85°C
	Junction Temperature Range.....-40°C to 125°C

Thermal Information

Parameter	Symbol	Package	Maximum	Unit
Thermal Resistance (Junction to ambient)	θ_{JA}	WCSP 1.45x1.45	90-220	°C/W
		MSOP-8	180	°C/W
		DFN 3x3-8	47.9	°C/W
Thermal Resistance (Junction to case)	θ_{JC}	MSOP-8	75	°C/W

Note: For the 9-pin CSP package, the thermal resistance is highly dependent on the PCB heat sink area. For example, the θ_{ja} can equal to 195°C/W with 50mm² total area or 135°C/W with 500mm² area. When using ground and power planes, the value is around 90°C/W.



PAM8303C

Ultra Low EMI, 3W Filterless Mono Class-D Audio Power Amplifier

Electrical Characteristic

$T_A=25^{\circ}\text{C}$, $V_{DD}=5\text{V}$, Gain=2V/V, $R_L=L(33\mu\text{H})+R+L(33\mu\text{H})$, unless otherwise noted.

Symbol	Parameter	Test Conditions	MIN	TYP	MAX	UNIT		
V_{DD}	Supply Voltage		2.8		5.5	V		
P_o	Output Power	THD+N=10%, f=1kHz, R=4 Ω	$V_{DD}=5.0\text{V}$	2.85	3.0		W	
			$V_{DD}=3.6\text{V}$	1.65	1.8			
			$V_{DD}=3.2\text{V}$	1.20	1.35			
		THD+N=1%, f=1kHz, R=4 Ω	$V_{DD}=5.0\text{V}$	2.50	2.66		W	
			$V_{DD}=3.6\text{V}$	1.15	1.3			
			$V_{DD}=3.2\text{V}$	0.85	1			
		THD+N=10%, f=1kHz, R=8 Ω	$V_{DD}=5.0\text{V}$	1.65	1.8		W	
			$V_{DD}=3.6\text{V}$	0.75	0.9			
			$V_{DD}=3.2\text{V}$	0.55	0.7			
		THD+N=1%, f=1kHz, R=8 Ω	$V_{DD}=5.0\text{V}$	1.3	1.5		W	
			$V_{DD}=3.6\text{V}$	0.55	0.72			
			$V_{DD}=3.2\text{V}$	0.40	0.55			
THD+N	Total Harmonic Distortion Plus Noise	$V_{DD}=5.0\text{V}, P_o=1\text{W}, R=8\Omega$	f=1kHz		0.28	0.35	%	
				$V_{DD}=3.6\text{V}, P_o=0.1\text{W}, R=8\Omega$		0.4		0.45
				$V_{DD}=3.2\text{V}, P_o=0.1\text{W}, R=8\Omega$		0.55		0.6
		$V_{DD}=5.0\text{V}, P_o=0.5\text{W}, R=4\Omega$	f=1kHz		0.2	0.25	%	
				$V_{DD}=3.6\text{V}, P_o=0.2\text{W}, R=4\Omega$		0.35		0.4
				$V_{DD}=3.2\text{V}, P_o=0.1\text{W}, R=4\Omega$		0.5		0.55
PSRR	Power Supply Ripple Rejection	$V_{DD}=3.6\text{V}$, Inputs ac-grounded with C=1 μF	f=217Hz		-63	-55	dB	
			f=1kHz		-62	-55		
			f=10kHz		-52	-40		
Dyn	Dynamic Range	$V_{DD}=5\text{V}$, THD=1%, R=8 Ω	f=1kHz	85	95			
V_n	Output Noise	Inputs ac-grounded	No A-weighting		50	100	μV	
			A-weighting		30	60		
CMRR	Common Mode Rejection Ratio	$V_{IC}=100\text{mVpp}, f=1\text{kHz}$		40	63		dB	

(To Be Cont'd)



PAM8303C

Ultra Low EMI, 3W Filterless Mono Class-D Audio Power Amplifier

Electrical Characteristic (continued)

$T_A=25^{\circ}\text{C}$, $V_{DD}=5\text{V}$, $\text{Gain}=2\text{V/V}$, $R_L=L(33\mu\text{H})+R+L(33\mu\text{H})$, unless otherwise noted.

Symbol	Parameter	Test Conditions		MIM	TYP	MAX	UNIT
η	Efficiency	$R_L=8\Omega$, THD=10%	$f=1\text{kHz}$	85	90		%
		$R_L=4\Omega$, THD=10%		80	86		
I_Q	Quiescent Current	$V_{DD}=5\text{V}$	$R=8\Omega$		7.5	10	mA
		$V_{DD}=3.6\text{V}$			4.6	7	
		$V_{DD}=3.0\text{V}$			3.6	5	
I_{SD}	Shutdown Current	$V_{DD}=3\text{V to }5\text{V}$	$V_{SD}=0.3\text{V}$		0.5	2	μA
R_{dson}	Static Drain-to-source On-state Resistor	CSP package, High Side PMOS plus Low Side NMOS, $I=500\text{mA}$	$V_{DD}=5\text{V}$		280	350	m Ω
			$V_{DD}=3.6\text{V}$		300	375	
			$V_{DD}=3\text{V}$		325	400	
		MSOP/DFN package, High Side PMOS plus Low Side NMOS, $I=500\text{mA}$	$V_{DD}=5\text{V}$		365	420	m Ω
			$V_{DD}=3.6\text{V}$		385	450	
			$V_{DD}=3\text{V}$		410	500	
R_i	Input Resistance				150		k Ω
f_{sw}	Switching Frequency	$V_{DD}=3\text{V to }5\text{V}$		200	250	300	kHz
G_v	Closed-loop Gain	$V_{DD}=3\text{V to }5\text{V}$			$300\text{k}\Omega/R_i$		V/V
V_{os}	Output Offset Voltage	Input ac-ground, $V_{DD}=5\text{V}$			10	50	mV
V_{IH}	Enable Input High Voltage	$V_{DD}=5\text{V}$		1.5			V
V_{IL}	Enable Input Low Voltage	$V_{DD}=5\text{V}$				0.3	



PAM8303C

Ultra Low EMI, 3W Filterless Mono Class-D Audio Power Amplifier

Typical Operating Characteristics

$T_A=25^\circ\text{C}$, $V_{DD}=5\text{V}$, $f=1\text{kHz}$, Gain=2V/V, unless otherwise noted.

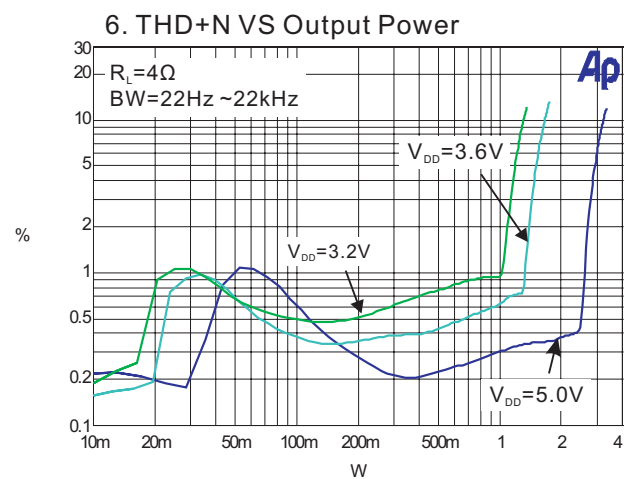
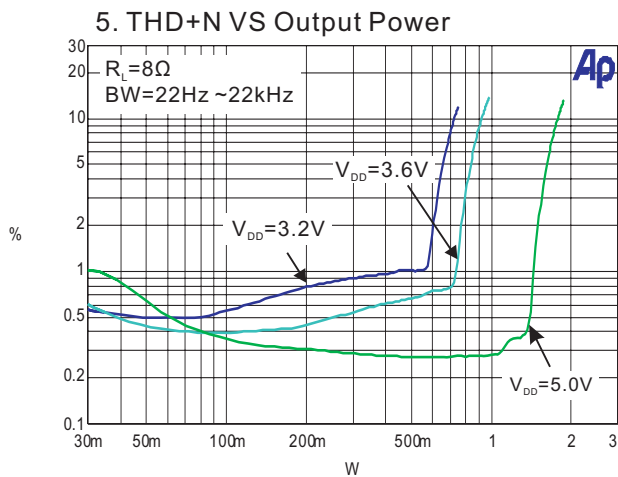
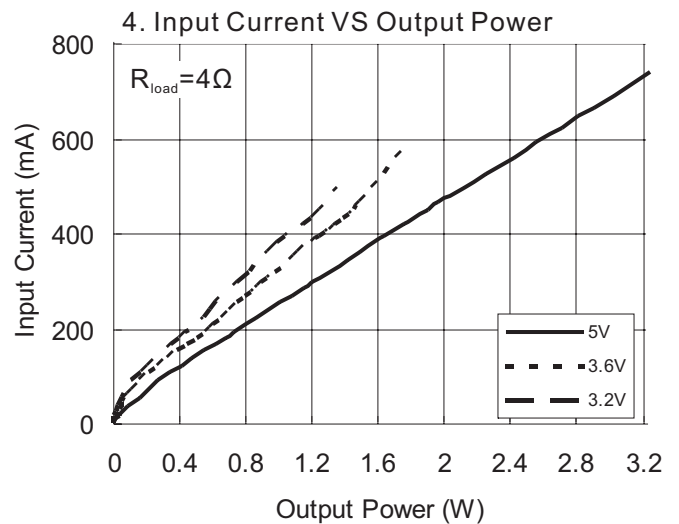
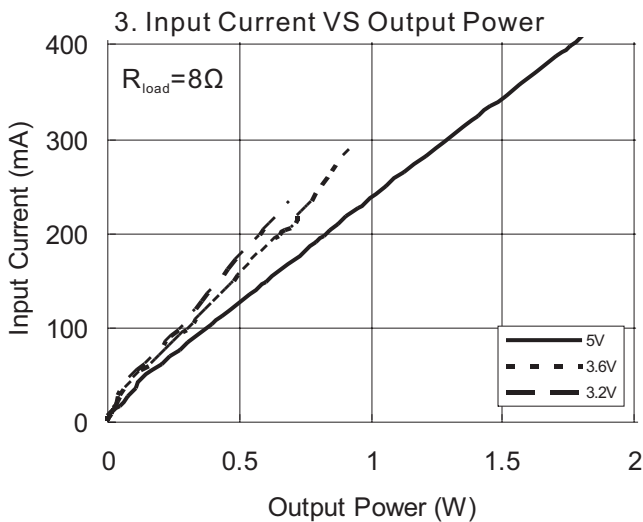
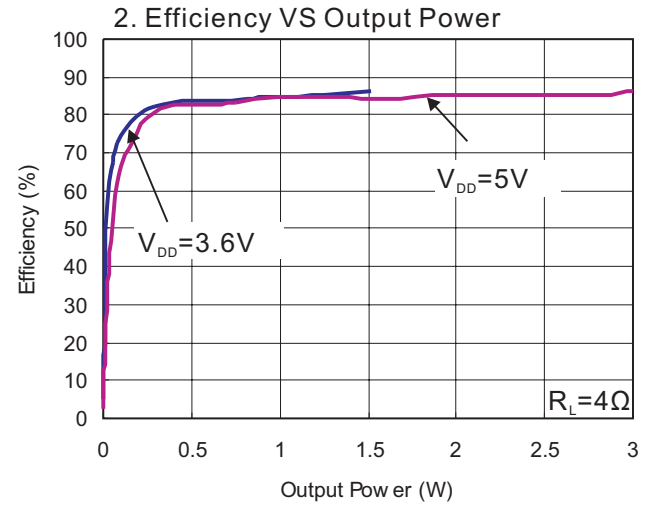
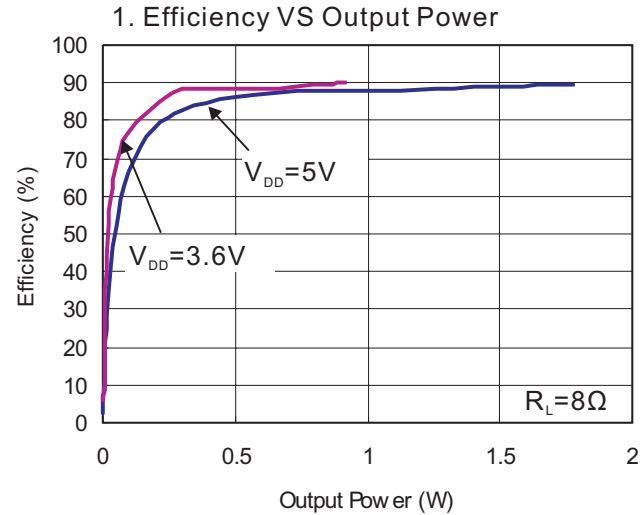



PAM8303C

Ultra Low EMI, 3W Filterless Mono Class-D Audio Power Amplifier

Typical Operating Characteristics

$T_A=25^\circ\text{C}$, $V_{DD}=5\text{V}$, $f=1\text{kHz}$, $\text{Gain}=2\text{V/V}$, unless otherwise noted.

7. THD+N VS Frequency

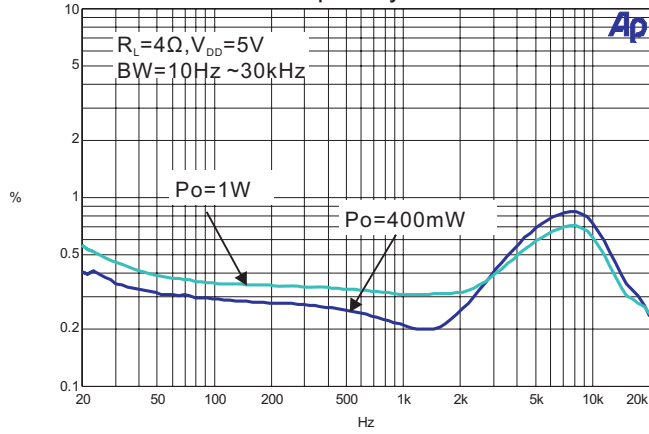

8. THD+N VS Frequency

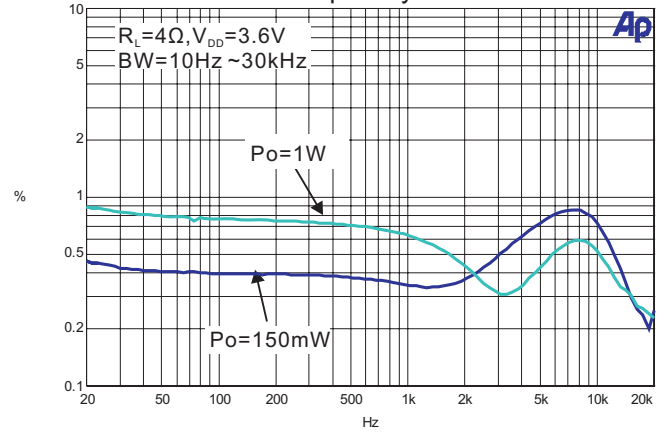

9. THD+N VS Frequency

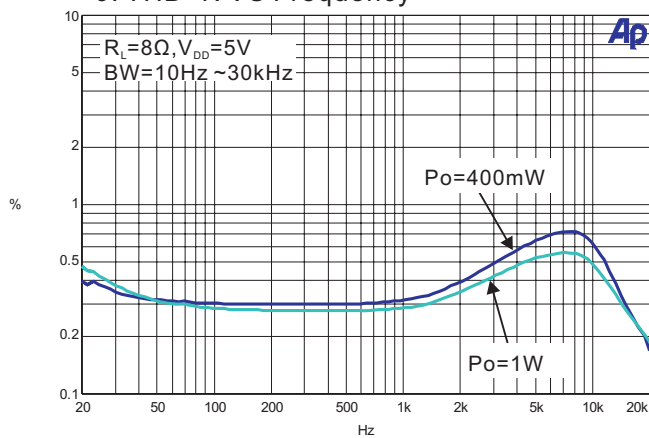

10. THD+N VS Frequency

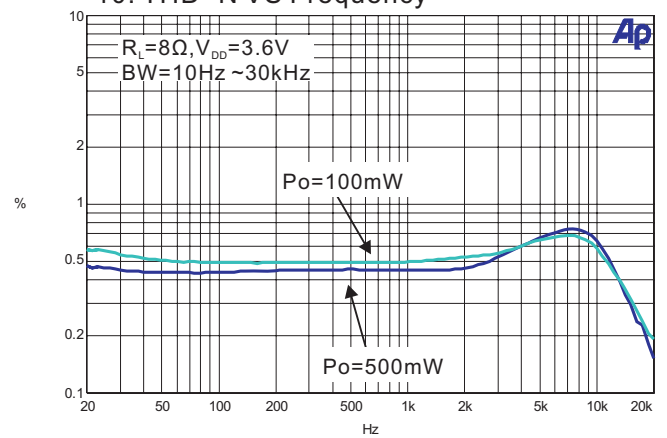



PAM8303C

Ultra Low EMI, 3W Filterless
Mono Class-D Audio Power Amplifier

Typical Operating Characteristics

$T_A=25^\circ\text{C}$, $V_{DD}=5\text{V}$, $f=1\text{kHz}$, $\text{Gain}=2\text{V/V}$, unless otherwise noted.

11. Frequency Response

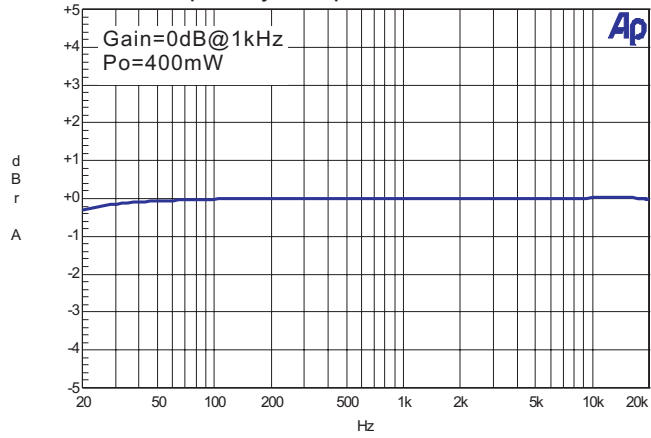

12. PSRR VS Frequency

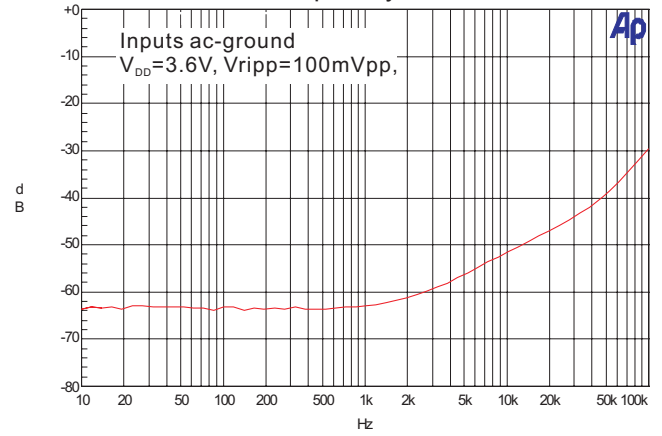

13. CMRR vs Frequency

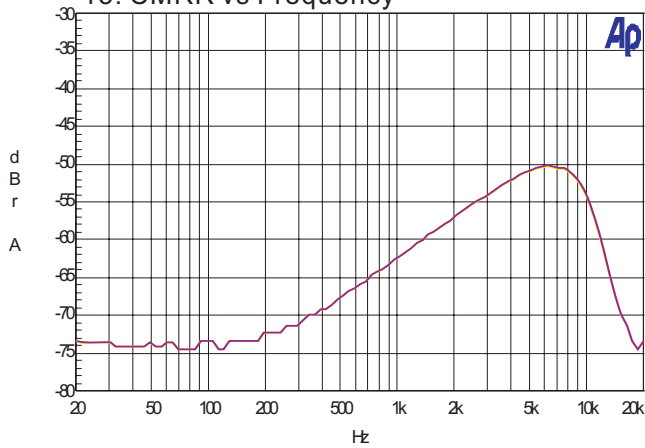

14. Noise FFT

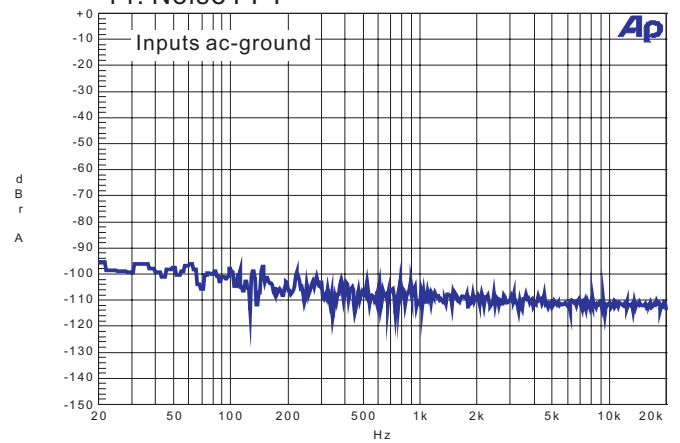



PAM8303C

Ultra Low EMI, 3W Filterless Mono Class-D Audio Power Amplifier

Typical Operating Characteristics

$T_A=25^\circ\text{C}$, $V_{DD}=5\text{V}$, $f=1\text{kHz}$, $\text{Gain}=2\text{V/V}$, unless otherwise noted.

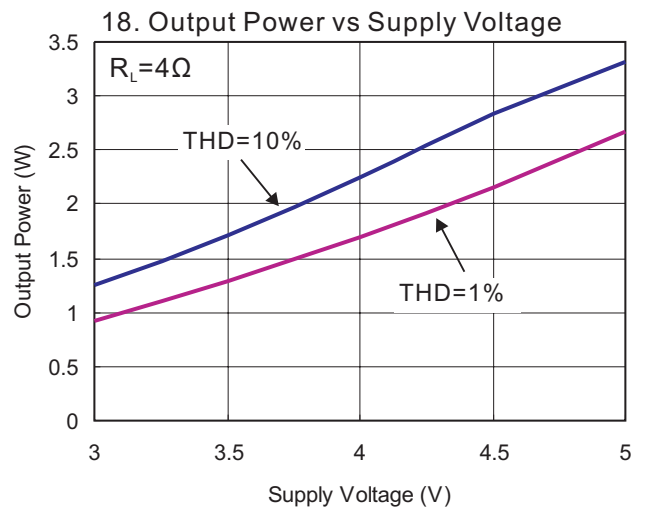
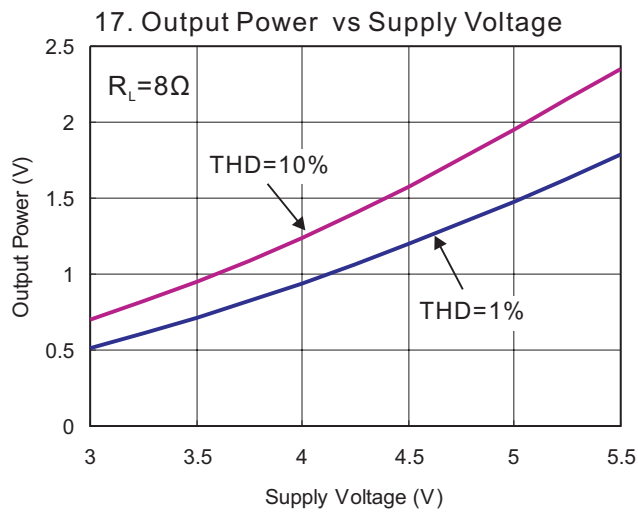
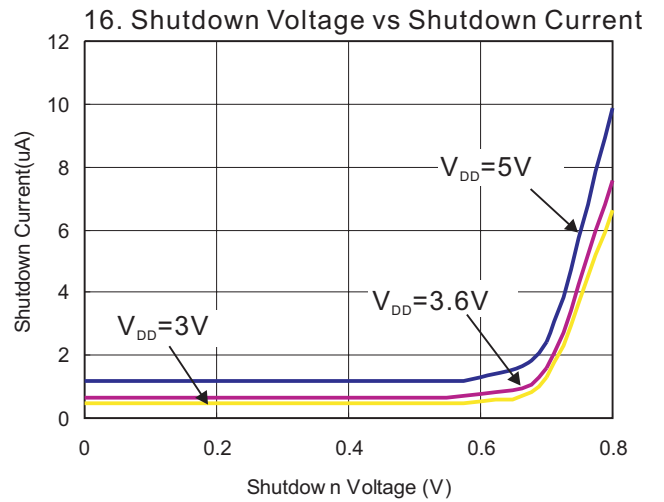
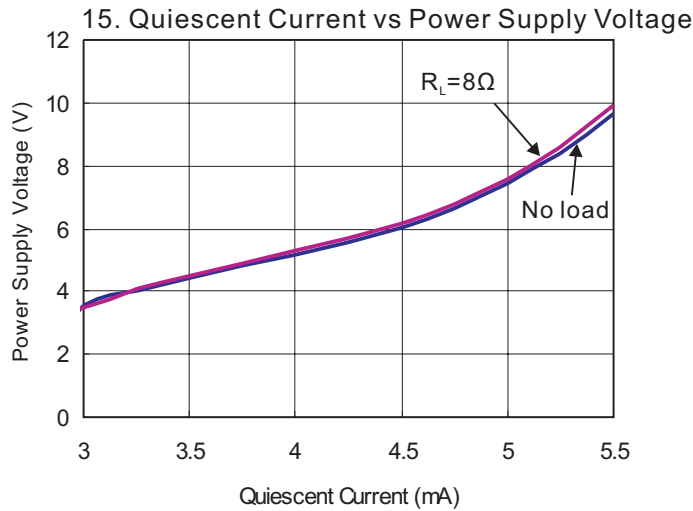

Typical Operating Characteristics

$T_A=25^\circ\text{C}$, $V_{DD}=5\text{V}$, $f=1\text{kHz}$, Gain=2V/V, unless otherwise noted.

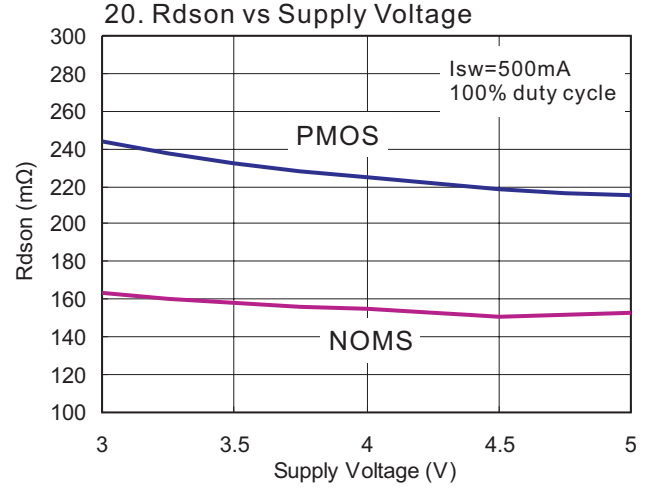
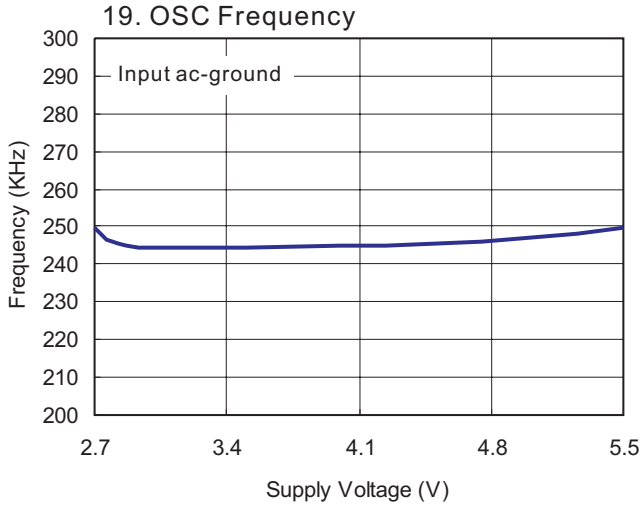

21. Start-up from Shutdown



Test Setup for Performance Testing

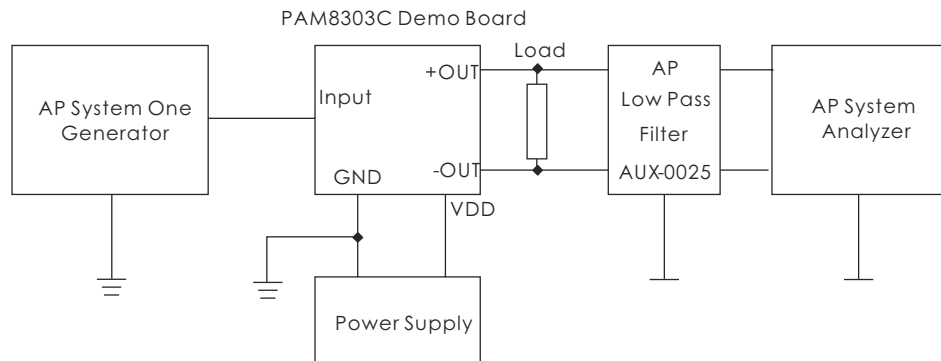

Notes

1. The APAUX-0025 low pass filter is necessary for class-D amplifier measurement with AP analyzer.
2. Two 22μH inductors are used in series with load resistor to emulate the small speaker for efficiency measurement.

Application Information

Input Resistance (R_i)

The input resistors (R_i) set the gain of the amplifier according to Equation 1.

$$\text{Gain} = \frac{2 \times 150\text{k}\Omega \left(\frac{V}{V} \right)}{R_i}$$

Resistor matching is very important in fully differential amplifiers. The balance of the output on the reference voltage depends on matched ratios of the resistors. CMRR, PSRR, and cancellation of the second harmonic distortion diminish if resistor mismatch occurs. Therefore, it is recommended to use 1% tolerance resistors or better to keep the performance optimized. Matching is more important than overall tolerance. Resistor arrays with 1% matching can be used with a tolerance greater than 1%.

Place the input resistors very close to the PAM8303C to limit noise injection on the high-impedance nodes.

For optimal performance the gain should be set to 2X(R_i=150k) or lower. Lower gain allows the PAM8303C to operate at its best, and keeps a high voltage at the input making the inputs less susceptible to noise. In addition to these features, higher value of R_i minimizes pop noise.

Input Capacitors (C_i)

In the typical application, an input capacitor, C_i, is required to allow the amplifier to bias the input signal to the proper DC level for optimum operation. In this case, C_i and the minimum input impedance R_i form a high-pass filter with the corner frequency determined in the follow equation:

$$f_c = \frac{1}{(2\pi R_i C_i)}$$

It is important to consider the value of C_i as it directly affects the low frequency performance of the circuit. For example, when R_i is 150kΩ and the specification calls for a flat bass response are down to 150Hz. Equation is reconfigured as followed:

$$C_i = \frac{1}{(2\pi R_i f_c)}$$

When input resistance variation is considered, the C_i is 7nF, so one would likely choose a value of 10nF. A further consideration for this capacitor is the leakage path from the input source through the input network (C_i, R_i + R_f) to the load. This leakage current creates a DC offset voltage at the input to the amplifier that reduces useful headroom, especially in high gain applications.

For this reason, a low-leakage tantalum or ceramic capacitor is the best choice. When polarized capacitors are used, the positive side of the capacitor should face the amplifier input in most applications as the DC level is held at V_{DD}/2, which is likely higher than the source DC level. Please note that it is important to confirm the capacitor polarity in the application.

Decoupling Capacitor (C_s)

The PAM8303C is a high-performance CMOS audio amplifier that requires adequate power supply decoupling to ensure the output total harmonic distortion (THD) as low as possible. Power supply decoupling also prevents the oscillations causing by long lead length between the amplifier and the speaker.

The optimum decoupling is achieved by using two different types of capacitors that target on different types of noise on the power supply leads. For higher frequency transients, spikes, or digital hash on the line, a good low equivalent-series-resistance (ESR) ceramic capacitor, typically 1μF, is placed as close as possible to the device each VDD and PVDD pin for the best operation. For filtering lower frequency noise signals, a large ceramic capacitor of 10μF or greater placed near the audio power amplifier is recommended.

How to Reduce EMI

Most applications require a ferrite bead filter for EMI elimination shown at Figure 1. The ferrite filter reduces EMI around 1MHz and higher. When selecting a ferrite bead, choose one with high impedance at high frequencies, but low impedance at low frequencies.

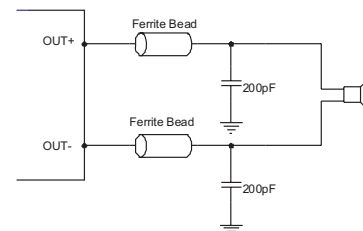

Figure 1: Ferrite Bead Filter to Reduce EMI

Shutdown operation

In order to reduce power consumption while not in use, the PAM8303C contains shutdown circuitry that is used to turn off the amplifier's bias circuitry. This shutdown feature turns the

amplifier off when logic low is placed on the \overline{SD} pin. By switching the shutdown pin connected to GND, the PAM8303C supply current draw will be minimized in idle mode.

Under Voltage Lock-out (UVLO)

The PAM8303C incorporates circuitry designed to detect low supply voltage. When the supply voltage drops to 2.3V or below, the PAM8303C goes into a state of shutdown, and the device comes out of its shutdown state and restore to normal function only when reset the power supply or \overline{SD} pin.

Short Circuit Protection (SCP)

The PAM8303C has short circuit protection circuitry on the outputs to prevent the device from damage when output-to-output shorts or output-to-GND shorts occur. When a short circuit occurs, the device immediately goes into shutdown state. Once the short is removed, the device will be reactivated.

Over Temperature Protection (OTP)

Thermal protection on the PAM8303C prevents the device from damage when the internal die temperature exceeds 135°C. There is a 15°C tolerance on this trip point from device to device. Once the die temperature exceeds the set point, the device will enter the shutdown state and the outputs are disabled. This is not a latched fault. The thermal fault is cleared once the temperature of the die decreased by 30°C. This large hysteresis will prevent motor boating sound well and the device begins normal operation at this point with no external system interaction.

POP and Click Circuitry

The PAM8303C contains circuitry to minimize turn-on and turn-off transients or “click and pops”, where turn-on refers to either power supply turn-on or device recover from shutdown mode. When the device is turned on, the amplifiers are internally muted. An internal current source ramps up the internal reference voltage. The device will remain in mute mode until the reference voltage reach half supply voltage, 1/2 VDD. As soon as the reference voltage is stable, the device will begin full operation. For the best power-off pop performance, the amplifier should be set in shutdown mode prior to removing the power supply voltage.

PCB Layout Guidelines

Grounding

It is recommended to use plane grounding or separate grounds. Do not use one line connecting power GND and analog GND. Noise currents in the output power stage need to be returned to output noise ground and nowhere else. When these currents circulate elsewhere, they may get into the power supply, or the signal ground, etc, even worse, they may form a loop and radiate noise. Any of these instances results in degraded amplifier performance. The output noise ground that the logical returns for the output noise currents associated with class D switching must tie to system ground at the power exclusively. Signal currents for the inputs, reference need to be returned to quiet ground. This ground only ties to the signal components and the GND pin. GND then ties to system ground.

Power Supply Line

As same to the ground, VDD and PVDD need to be separately connected to the system power supply. It is recommended that all the trace could be routed as short and thick as possible. For the power line layout, just imagine water stream, any barricade placed in the trace (shown in figure 2) could result in the bad performance of the amplifier.

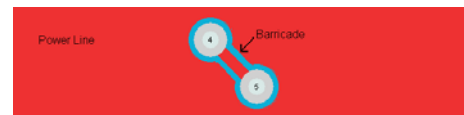

Figure 2: Power Line

Components Placement

Decoupling capacitors-As previously described, the high-frequency 1μF decoupling capacitors should be placed as close to the power supply terminals (VDD and PVDD) as possible. Large bulk power supply decoupling capacitors (10μF or greater) should be placed near the PAM8303C on the PVDD terminal.

Input resistors and capacitors need to be placed very close to input pins.

Output filter - The ferrite EMI filter should be placed as close to the output terminals as possible for the best EMI performance, and the capacitors used in the filters should be grounded to system ground.



PAM8303C

Ultra Low EMI, 3W Filterless
Mono Class-D Audio Power Amplifier

Ordering Information

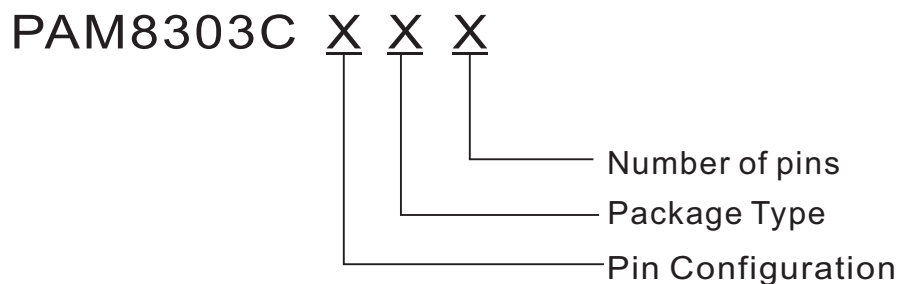

Pin Configuration	Package Type	Number of pins
A	Z: WCSP	C: 8
B	Y: DFN 3x3	N: 9
C	S: MSOP	
(Refer to P2,3 Pin Configuration)		

Part Number	Marking	Package Type	MOQ
PAM8303CAZN	BH YW	WCSP 9	3,000 Units/ Tape & Reel
PAM8303CBYC	P8303C XXXYW	DFN 3x3	3,000 Units/ Tape & Reel
PAM8303CCYC	P8303C XXXYW	DFN 3x3	3,000 Units/ Tape & Reel
PAM8303CBSC	P8303C XXXYW	MSOP-8	2,500 Units/ Tape & Reel

Outline Dimensions

WCSP

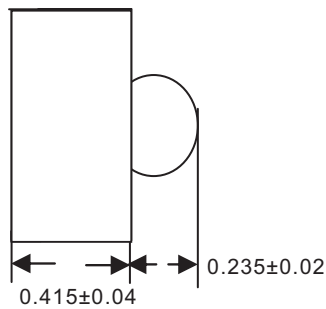
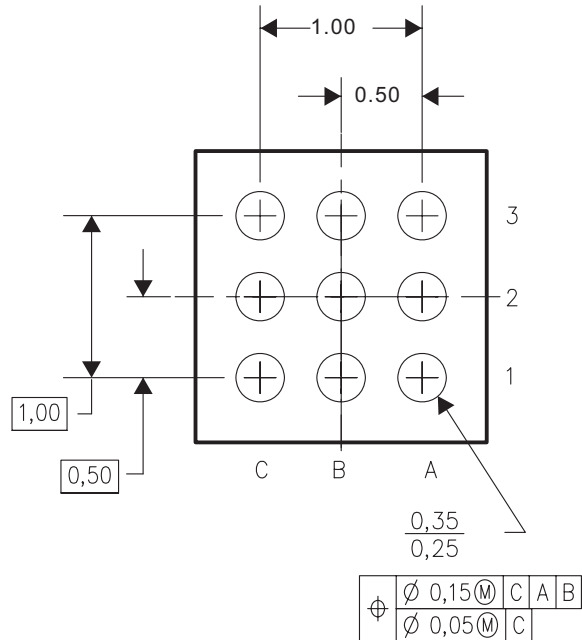
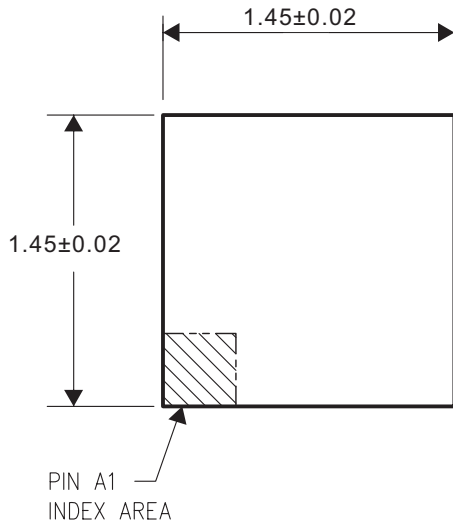

Unit: Millimeter

Outline Dimensions

MSOP8

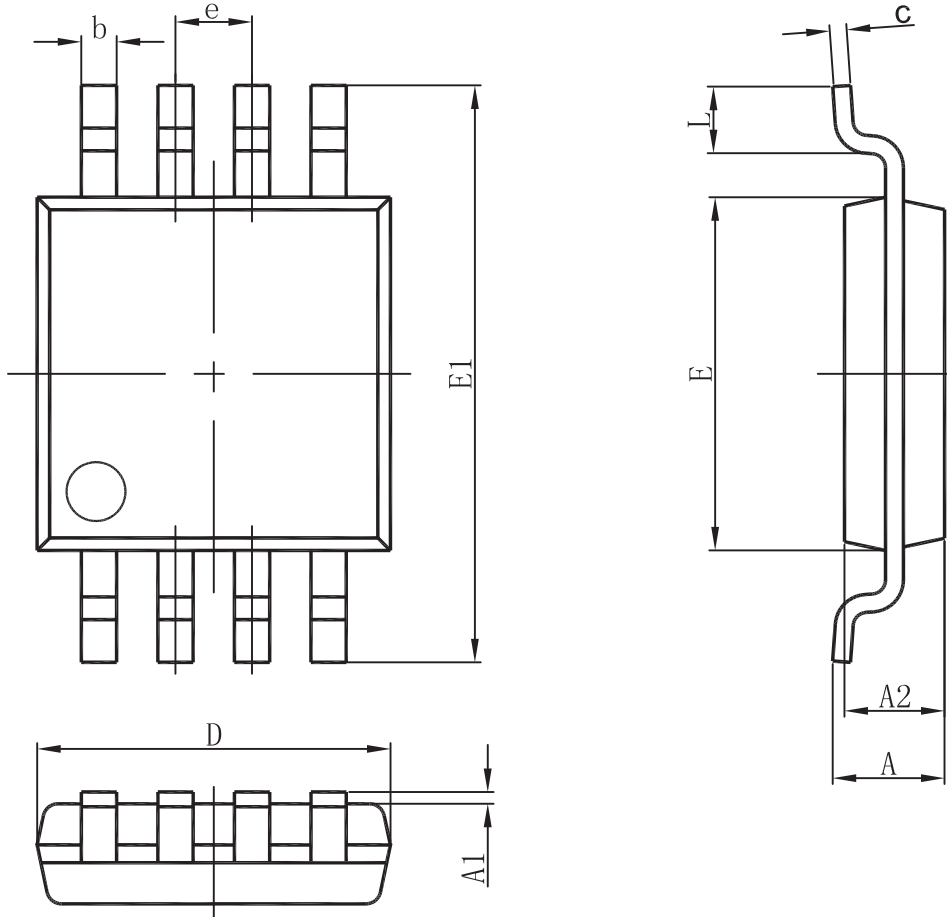

REF	Millimeter	
	Min	Max
A	--	1.10
A1	0.05	0.15
A2	0.78	0.94
b	0.22	0.38
c	0.08	0.23
D	2.90	3.10
E	2.90	3.10
E1	4.75	5.05
e	0.65BSC	
L	0.40	0.70

Outline Dimensions

DFN 3x3

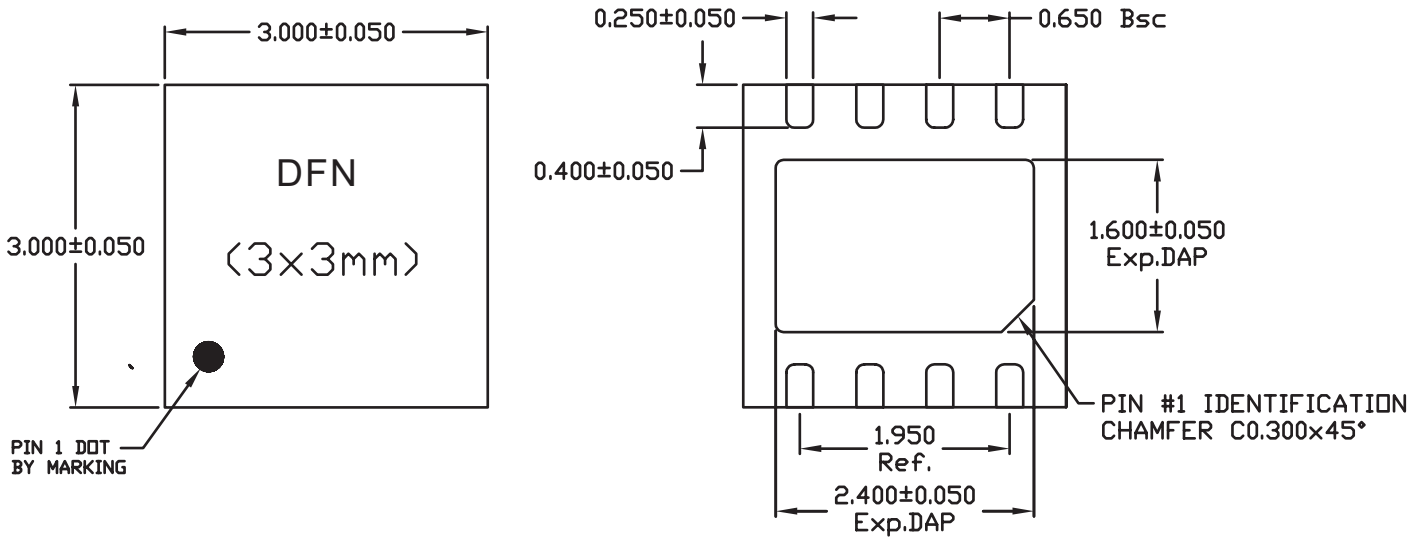

A	MAX.	0.800
	NOM.	0.750
	MIN.	0.700

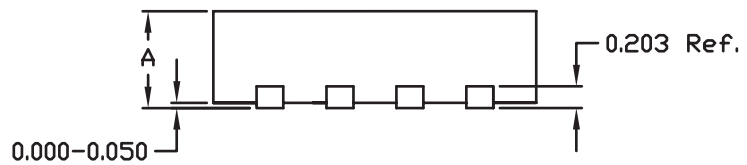

Unit: Millimeter