

### Key Features

- 1.5W Output at 10% THD with a 8Ω Load and 5V Power Supply
- Filterless, Low Quiescent Current and Low EMI
- High Efficiency up to 88%
- Superior Low Noise
- Short Circuit Protection
- Thermal Shutdown
- Few External Components to Save Space and Cost
- Tiny SOT23-6 Package
- Pb-Free Package

### Applications

- PMP/MP4
- GPS
- Portable Speakers
- Walkie Talkie
- Handsfree phones/Speaker Phones
- Cellular Phones

### General Description

The PAM8301 is a 1.5W class-D mono audio amplifier. Its low THD+N feature offers high-quality sound reproduction. The new filterless architecture allows the device to drive speaker directly instead of using low-pass output filters, therefore save system cost and PCB area.

With the same number of external components, the efficiency of the PAM8301 is much better than that of class-AB cousins. It can optimize battery life thus is ideal for portable applications.

The PAM8301 is available in SOT23-6 package.

### Typical Application

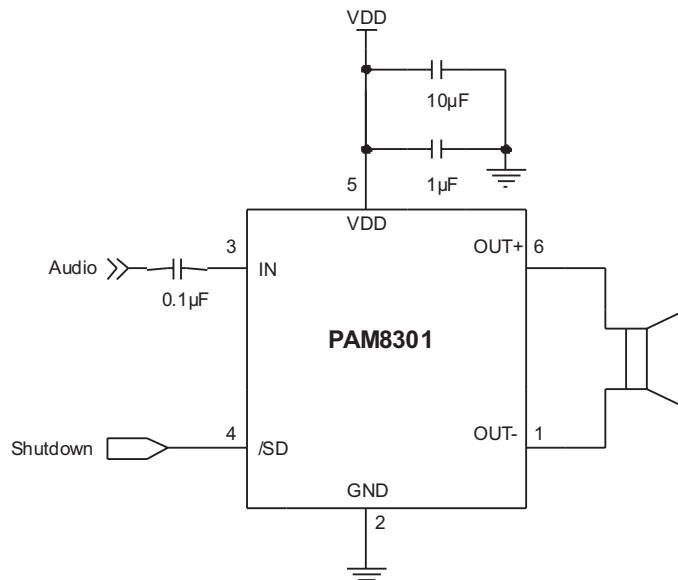

### Block Diagram

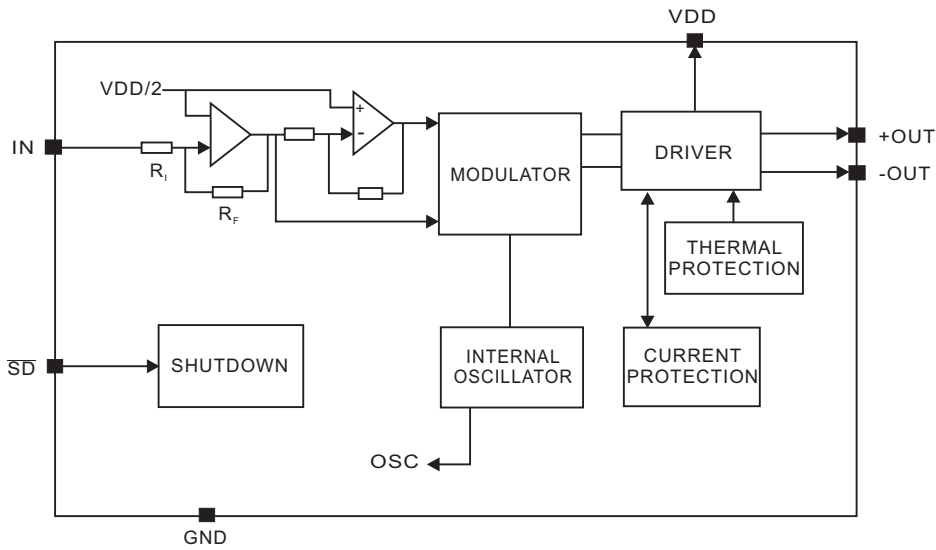

### Pin Configuration & Marking Information

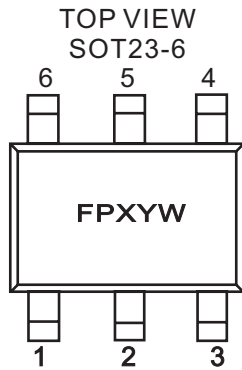

FP: Product Code of PAM8301  
 X: Internal Code  
 Y: Year  
 W: Week

Pin Number	Pin Name	Description
1	OUT-	Negative Output
2	GND	Ground
3	IN	Input
4	$\overline{\text{SD}}$	Shutdown, active low
5	VDD	Power Supply
6	OUT+	Positive Output



### Absolute Maximum Ratings

These are stress ratings only and functional operation is not implied. Exposure to absolute maximum ratings for prolonged time periods may affect device reliability. All voltages are with respect to ground.

Supply Voltage at no Input Signal.....6.0V      Maximum Junction Temperature.....150°C  
Input Voltage.....-0.3V to  $V_{DD}+0.3V$       Storage Temperature.....-65°C to 150°C  
Soldering Temperature.....300°C, 5sec

### Recommended Operating Conditions

Supply voltage Range.....2.5V to 5.5V      Operation Temperature Range..... -40°C to 85°C  
Junction Temperature Range.....-40°C to 125°C

### Thermal Information

Parameter	Symbol	Package	Maximum	Unit
Thermal Resistance (Junction to Case)	$\theta_{JC}$	SOT23-6	130	°C/W
Thermal Resistance (Junction to Ambient)	$\theta_{JA}$	SOT23-6	250	



### Electrical Characteristic

$V_{DD}=5V$ , Gain = 24dB,  $R_L=8\Omega$ ,  $T_A=25^\circ C$ , unless otherwise noted.

PARAMETER	SYMBOL	CONDITIONS	MIN	TYP	MAX	UNITS
Supply Voltage Range	$V_{DD}$		2.5		5.5	V
Quiescent Current	$I_Q$	No Load		4	8	mA
Shutdown Current	$I_{SHDN}$	$V_{SHDN}=0V$			1	$\mu A$
$\overline{SHDN}$ Input High	$V_{SH}$		1.2			V
$\overline{SHDN}$ Input Low	$V_{SL}$				0.4	
Drain-Source On-State Resistance	$R_{DS(ON)}$	$I_{DS}=100mA$	P MOSFET		0.45	$\Omega$
			N MOSFET		0.20	
Output Power	$P_O$	$f=1kHz$	THD+N=1%		1.2	W
			THD+N=10%		1.5	
Total Harmonic Distortion Plus Noise	THD+N	$R_L = 8\Omega$ , $P_O=200mW$		0.2		%
		$R_L = 8\Omega$ , $P_O=0.5W$		0.3		
Power Supply Ripple Rejection	PSRR	No input, $f=1kHz$ , $V_{pp}=200mV$	45	50		dB
Gain	$G_v$			24		dB
Noise	$V_n$	No A-weighting		180		$\mu V$
		A-weighting		120		
Oscillator Frequency	$f_{OSC}$		200	250	300	kHz
Peak Efficiency	$\eta$	$f=1kHz$	85	88		%
Signal to Noise Ratio	SNR	$f=20$ to $20kHz$		78		dB
Over Temperature Protection	OTP			135		$^\circ C$
Over Temperature Hysteresis	OTH			30		$^\circ C$

### Typical Performance Characteristic

$T_A = 25^\circ\text{C}$ , unless otherwise noted.

1. Frequency VS Supply Voltage

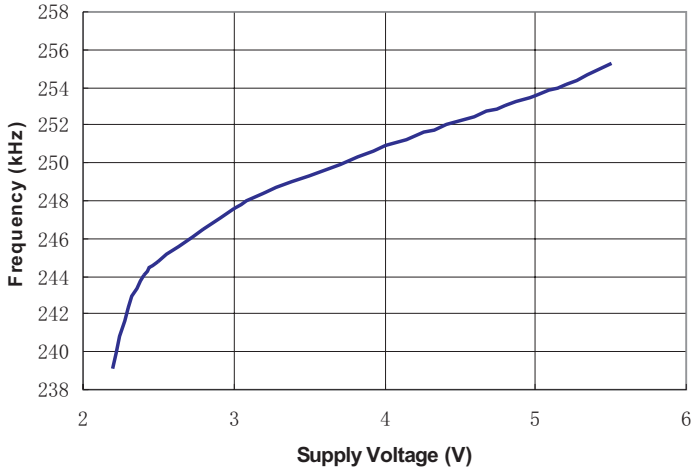

2. Frequency VS Temperature

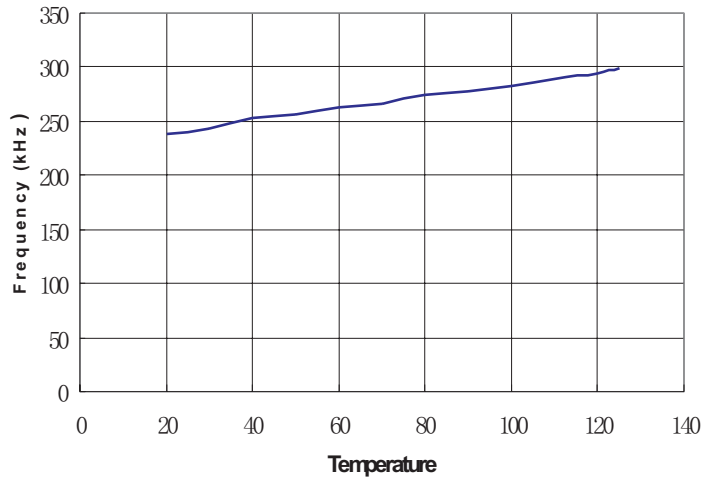

3. Efficiency VS Output Power

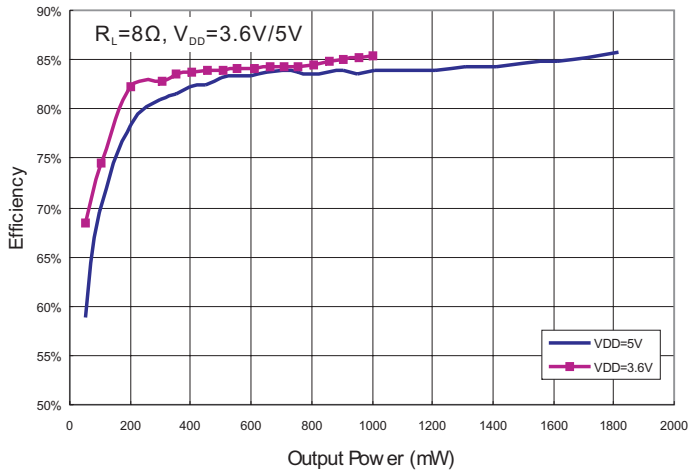

4. Efficiency VS Output Power

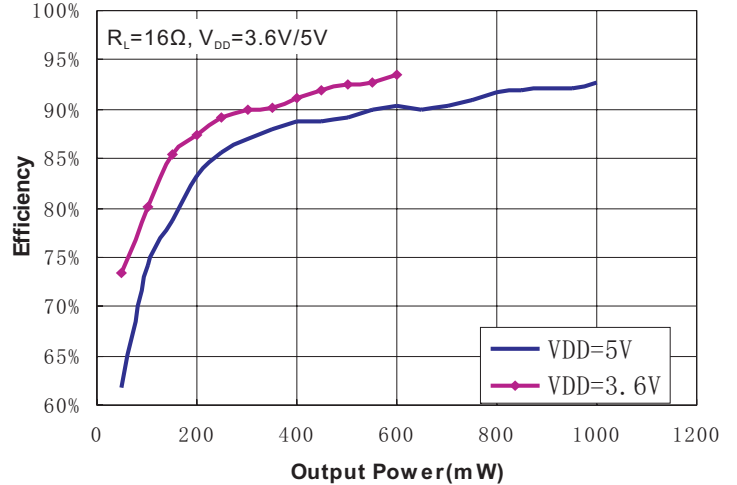

5. THD+N VS Output Power

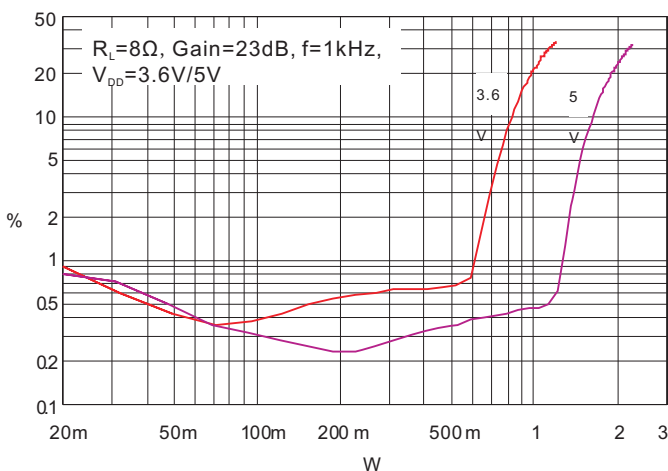

6. THD+N VS Output Power

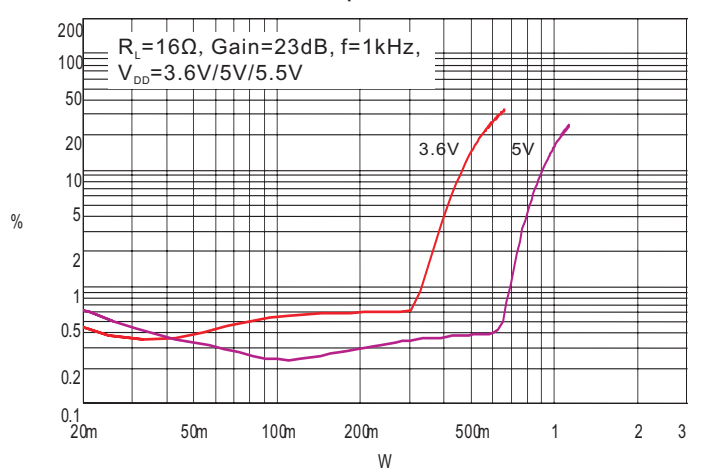

### Typical Performance Characteristic

$T_A=25^\circ\text{C}$ , unless otherwise noted.

7. THD+N VS Frequency

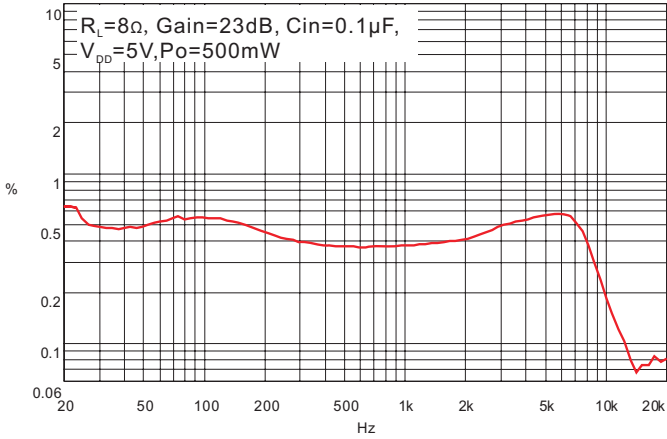

8. THD+N VS Frequency

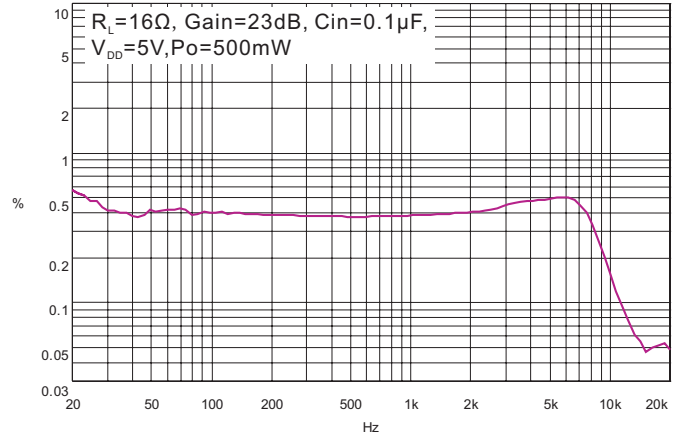

9. THD+N VS Frequency

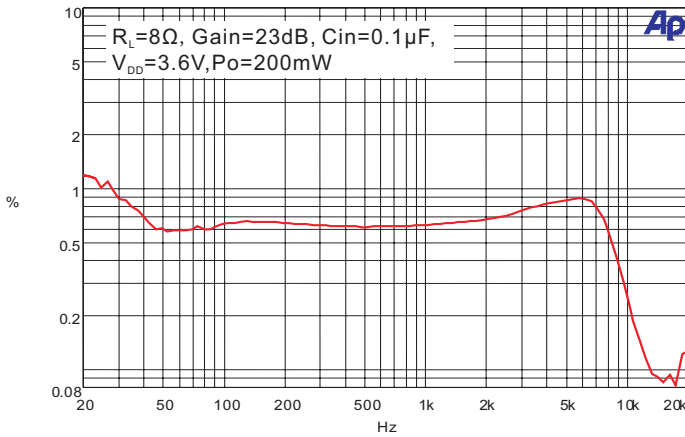

10. THD+N VS Frequency

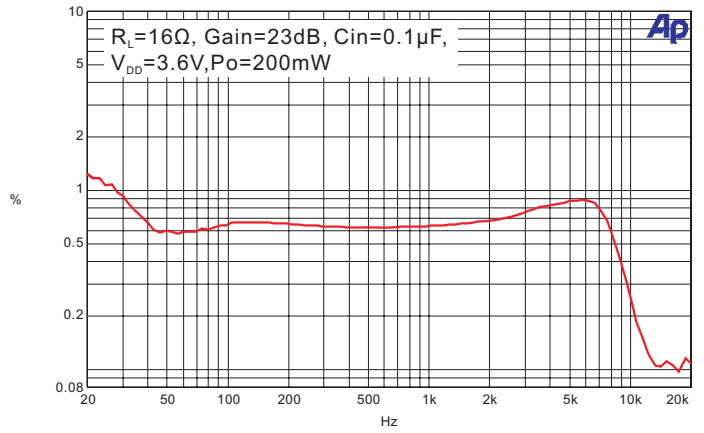

11. Frequency Response

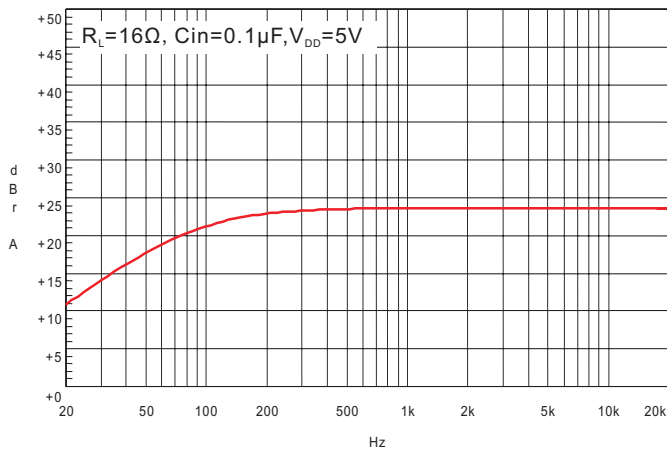

12. Noise Floor

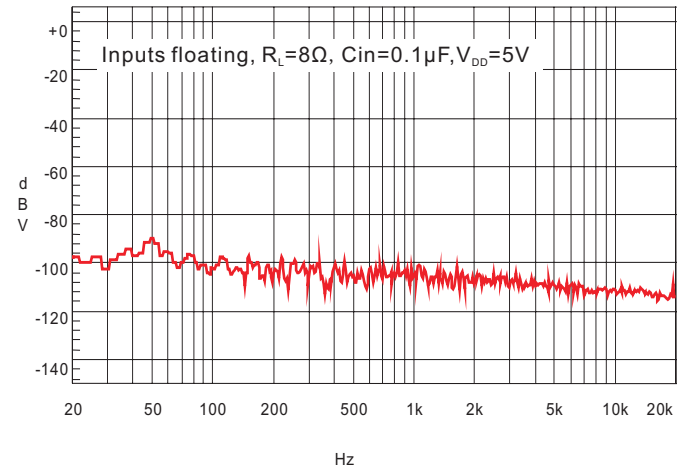

### Typical Performance Characteristic

$T_A = 25^\circ\text{C}$  unless otherwise noted.

13. PSRR

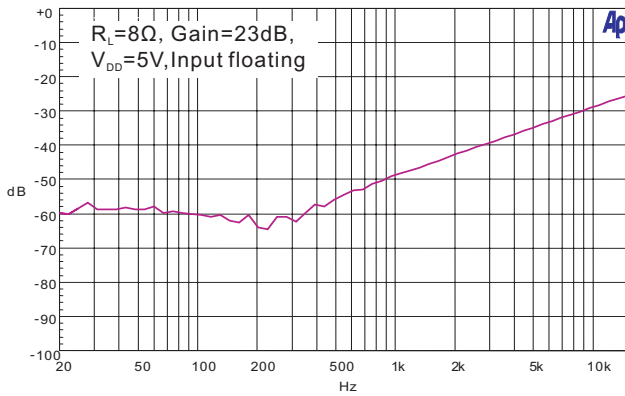

14. EMI vs Frequency

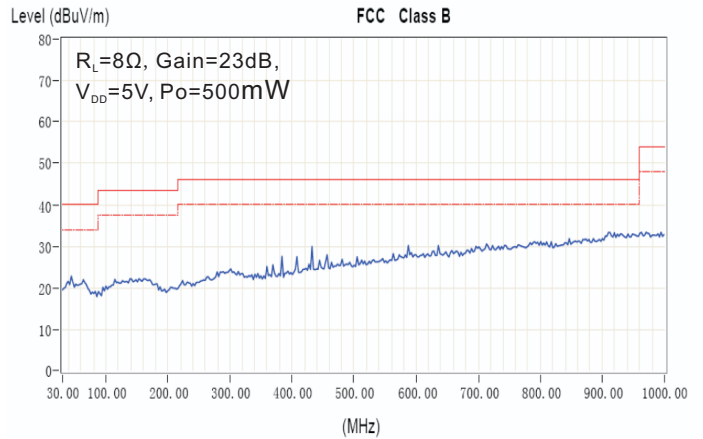

### Test Setup for Performance Testing

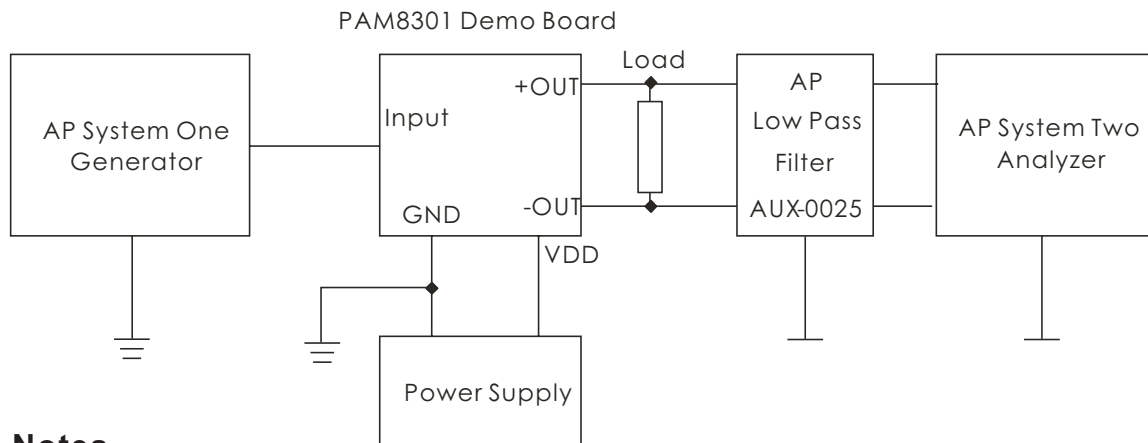

#### Notes

1. The AP AUX-0025 low pass filter is necessary for every class-D amplifier measurement with AP analyzer.
2. Two  $22\mu\text{H}$  inductors are used in series with load resistor to emulate the small speaker for efficiency measurement.

### Application Information

#### Maximum Gain

As shown in block diagram (page 2), the PAM8301 has two internal amplifier stages. The first stage's gain is externally configurable, while the second stage's is internally fixed. The closed-loop gain of the first stage is set by selecting the ratio of  $R_f$  to  $R_i$  while the second stage's gain is fixed at 2x. The output of amplifier 1 serves as the input to amplifier 2, thus the two amplifiers produce signals identical in magnitude, but different in phase by 180°. Consequently, the differential gain for the IC is

$$A_{VD} = 20 \cdot \log [2 \cdot (R_f/R_i)]$$

The PAM8301 sets maximum  $R_f = 80k\Omega$ , minimum  $R_i = 10k\Omega$ , so the maximum closed-gain is 24dB.

#### Input Capacitors ( $C_i$ )

In typical application, an input capacitor,  $C_i$ , is required to allow the amplifier to bias input signals to a proper DC level for optimum operation. In this case,  $C_i$  and the minimum input impedance  $R_i$  (10k internal) form a high pass filter with a corner frequency determined by the following equation:

$$f_c = \frac{1}{(2\pi R_i C_i)}$$

It is important to choose the value of  $C_i$  as it directly affects low frequency performance of the circuit, for example, when an application requires a flat bass response as low as 100Hz. Equation is reconfigured as follows:

$$C_i = \frac{1}{(2\pi R_i f_c)}$$

As the input resistance is variable, for the  $C_i$  value of 0.16 $\mu$ F, one should actually choose the  $C_i$  within the range of 0.1 $\mu$ F to 0.22 $\mu$ F. A further consideration for this capacitor is the leakage path from the input source through the input network ( $R_i$ ,  $R_f$ ,  $C_i$ ) to the load. This leakage current creates a DC offset voltage at the input to the amplifier that reduces useful headroom, especially in high gain application. For this reason, a low leakage tantalum or ceramic

capacitor is the best choice. When a polarized capacitor is used, the positive side of the capacitor should face the amplifier input in most applications as the DC level is held at  $V_{DD}/2$ , which is likely higher than the source DC level. Please note that it is important to confirm the capacitor polarity in the application.

#### Power Supply Decoupling ( $C_s$ )

The PAM8301 is a high-performance CMOS audio amplifier that requires adequate power supply decoupling to ensure the output THD and PSRR as low as possible. Power supply decoupling affects low frequency response. Optimum decoupling is achieved by using two capacitors of different types that target different types of noise on the power supply leads. For higher frequency transients, spikes, or digital hash on the line, a good low equivalent-series-resistance (ESR) ceramic capacitor, typically 1.0 $\mu$ F is good, placing it as close as possible to the device VDD terminal. For filtering lower-frequency noise signals, a capacitor of 10 $\mu$ F or

larger, closely located to near the audio power amplifier is recommended.

#### Shutdown Operation

In order to reduce shutdown power consumption, the PAM8301 contains shutdown circuitry for turn off the amplifier. This shutdown feature turns the amplifier off when a logic low is applied on the SHDOWN pin. By switching the shutdown pin over to GND, the PAM8301 supply current draw will be minimized in idle mode.

**For the best power on/off pop performance, the amplifier should be set in the shutdown mode prior to power on/off operation.**

#### Under Voltage Lock-out (UVLO)

The PAM8301 incorporates circuitry to detect low on or off voltage. When the supply voltage drops to 2.1V or below, the PAM8301 goes into a state of shutdown, and the device comes out of its shutdown state and starts to normal operation by reset the power supply or  $\overline{SD}$  pin.

### How to Reduce EMI (Electro Magnetic Interference)

A simple solution is to put an additional capacitor  $1000\mu\text{F}$  at power supply terminal for power line coupling if the traces from amplifier to speakers are short ( $<20\text{cm}$ ).

Most applications require a ferrite bead filter as shown at Figure 1. The ferrite filter depresses EMI of around  $1\text{MHz}$  and higher. When selecting a ferrite bead, choose one with high impedance at high frequencies and low impedance at low frequencies.

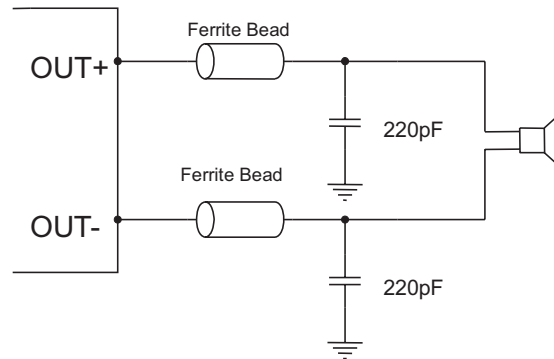
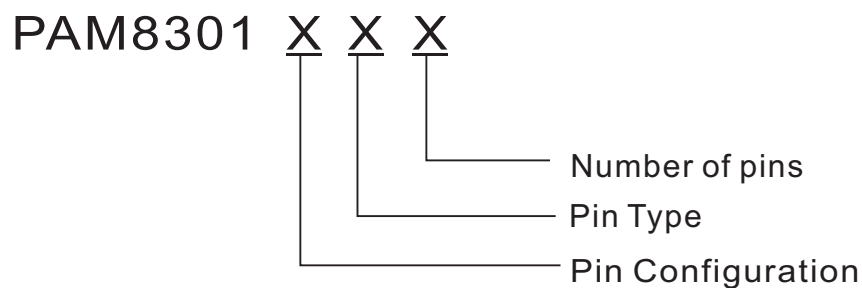

Figure 1: Ferrite Bead Filter to Reduce EMI

### Ordering Information



Pin Configuration	Package Type	Number of pins
A: 1: OUT- 2: GND 3: IN 4: $\overline{SD}$ 5: VDD 6: OUT+	A: SOT23-6	F: 6

Part Number	Marking	Package Type	Standard Package
PAM8301AAF	FPXYW	SOT23-6	3,000 Units/Tape & Reel

### Outline Dimensions

SOT23-6

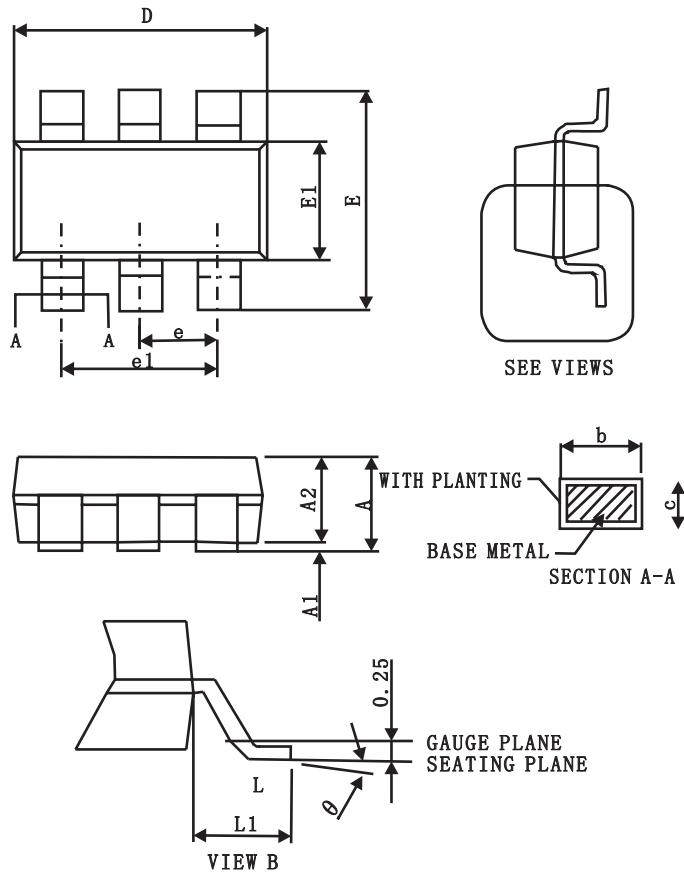

Symbol	A	A1	A2	b	c	D	E
Spec	1.20±0.25	0.10±0.05	1.10±0.2	0.40±0.1	0.15±0.07	2.90±0.1	2.80±0.2
Symbol	E1	e	e 1	L	L1	$\theta$	
Spec	1.60±0.1	0.95BSC	1.90BSC	0.55±0.25	0.60REF	4°±4°	

Unit: Millimeter