

Features

- Low-Dropout Regulator Supports Input Voltages Down to 1.4V
- Output Voltage Available in 0.9V, 1.0V, 1.2V, 1.5V, 1.8V, 2.5V, 2.8V, 2.85V, 3.0V, 3.3V
- Low Dropout Voltage: 300mV@3A
- Stable with a Ceramic Output Capacitor of 1.0µF or Higher
- Low Quiescent Current
- Current Limit
- Over Temperature Shutdown
- Short Circuit Current Protection
- Low Temperature Coefficient
- Standard TO-263, TO-220 and PSOP-8 (Exposed Pad) Packages
- Pb-Free Package

General Description

The PAM3130 is a 3A CMOS LDO regulator that features a low quiescent current, ultra low input, output, and dropout voltages, as well as over temperature protection. It is available in TO-263, TO-220 and PSOP-8 (Exposed Pad) packages. The fixed output voltage of the PAM3130 is set at the factory and trimmed to ±2.0%. The PAM3130 is stable with a ceramic output capacitor of 1.0µF or higher.

This family of regulators can provide either a stand-alone power supply solution or act as a post regulator for switch mode power supplies. They are particularly well suited for applications requiring low input and output voltages.

Applications

- DSP, FPGA, and Microprocessor Power Supplies
- 1.2V Core Voltage for DSPs
- SATA Power Supply
- LCD TV/ Monitors
- Wireless Devices
- Communication Devices
- Portable Electronics
- Post Regulator for SMPS

Typical Application

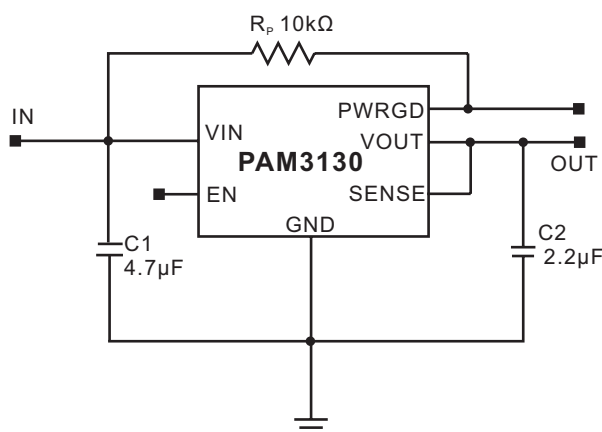
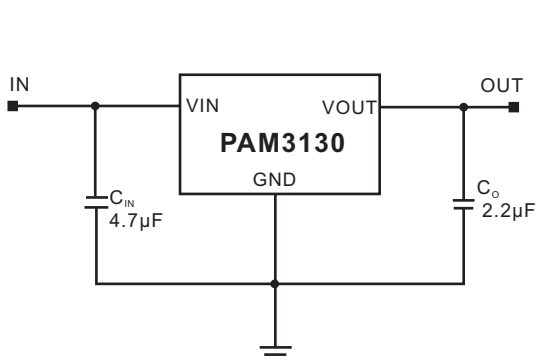

Block Diagram

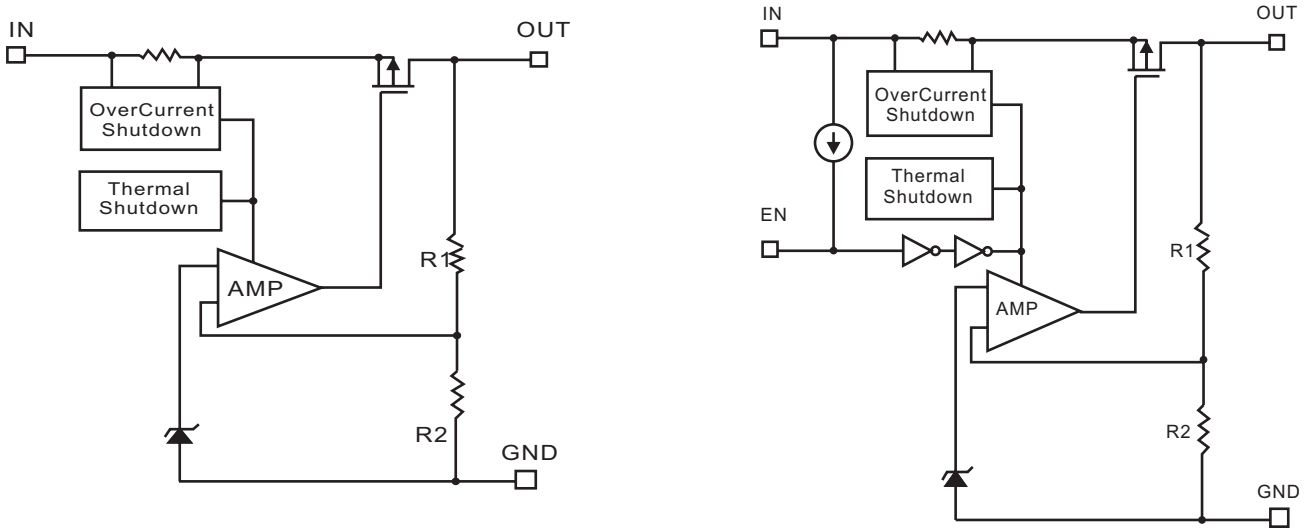

Pin Configuration & Marking Information

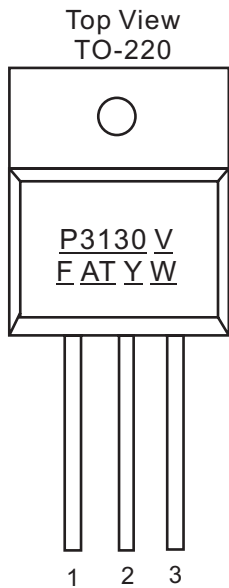

V: Voltage Code
 F: Internal Code
 A: Assembly Code
 T: Testing Code
 Y: Year
 W: Week

Pin Number	Name	Function
1	VIN	Input
2	GND	Ground (Heatsink)
3	VOUT	Output

Pin Configuration & Marking Information (continued)

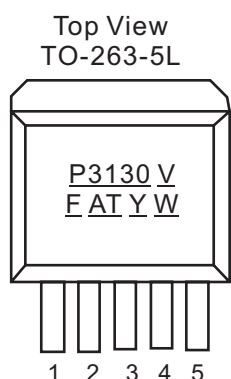

V: Voltage Code
 F: Internal Code
 A: Assembly Code
 T: Testing Code
 Y: Year
 W: Week

Pin Number	Name	Function
1	VIN	Input
2	EN	Enable Pin
3	GND	Ground (Heatsink)
4	PWRGD/SENSE	Power Good/Sense
5	VOUT	Output

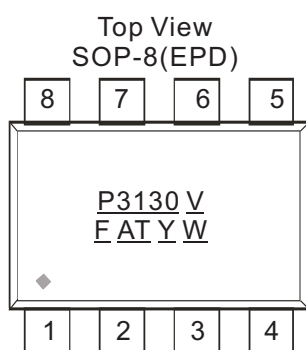

V: Voltage Code
 F: Internal Code
 A: Assembly Code
 T: Testing Code
 Y: Year
 W: Week

Pin Number	Name	Function
1	GND	Ground
2	VIN	Input
3	EN	Enable Pin
4	GND	Ground
5	PWRGD	Power Good
6	SENSE	Sense
7	VOUT	Output
8	GND	Ground



Absolute Maximum Ratings

These are stress ratings only and functional operation is not implied. Exposure to absolute maximum ratings for prolonged time periods may affect device reliability. All voltages are with respect to ground.

Input Voltage.....	4.0V	Storage Temperature.....	-65°C to 150°C
Output Pin Voltage.....	-0.3V to $V_{IN} + 0.3V$	Maximum Junction Temperature.....	150°C
Maximum Output Current.....	$P_D / (V_{IN} - V_O)$	Soldering Temperature.....	300°C, 5sec

Recommended Operating Conditions

Supply Voltage Range.....	1.4V to 3.6V	Junction Temperature Range.....	-40°C to 125°C
		Ambient Temperature Range.....	-40°C to 85°C

Thermal Information

Parameter	Symbol	Package	Maximum	Unit
Thermal Resistance (Junction to Case)	θ_{JC}	TO-263	7	°C/W
		TO-220	7	
		PSOP-8	11	
Thermal Resistance (Junction to Ambient)	θ_{JA}	TO-263	60	
		TO-220	50	
		PSOP-8	90	
Internal Power Dissipation	P_D	TO-263	2.8	W
		TO-220	3	



Electrical Characteristic

$V_{IN}=V_O+0.5V$, $T_A=25^\circ C$, $C_{IN}=4.7\mu F$, $C_O=2.2\mu F$, unless otherwise noted.

Parameters	Symbol	Test Conditions	MIN	TYP	MAX	UNITS		
Input Voltage Range	V_{IN}		Note 1		3.6	V		
Output Voltage Accuracy	V_O	$I_O=100mA$	-2		2	%		
Dropout Voltage	V_{DROD}	$I_O=500mA$	$V_O=0.9V$		330	500	mV	
			$V_O=1.0V$		220	400		
			$2.5V > V_O \geq 1.2V$		50	200		
			$V_O \geq 2.5V$		40	150		
		$I_O=3.0A$	$V_O=0.9V$		500			
			$V_O=1.0V$		400			
			$2.5V > V_O \geq 1.2V$		350			
			$V_O \geq 2.5V$		300			
Short Circuit Current	I_{SC}	$V_O < 0.3V$		1.0		A		
Output Current	I_O		3.0		Note 2	A		
Quiescent Current	I_Q	$I_O=0mA$		90	150	μA		
Ground Pin Current	I_{GND}	$I_O=1mA$ to $3.0A$			1.0	mA		
Line Regulation	LNR	$V_O \leq 2.5V, I_O=10mA$ $V_{IN}=V_O+0.5V$ to $V_O+1.5V$		0.5	1.0	%/ V		
		$V_O > 2.5V, I_O=10mA$ $V_{IN}=3.3V$ to $3.6V$						
Load Regulation	LDR	$I_O=1mA$ to $3.0A, V_{IN}=V_O+0.5V$		0.5	2	%/ A		
Over Temperature Shutdown	OTS			150		$^\circ C$		
Over Temperature Hysteresis	OTH			50		$^\circ C$		
Temperature Coefficient	TC			40		ppm/ $^\circ C$		
Power Supply Ripple Rejection	PSRR	$I_O=100mA, V_O=1.5V$	$f=100Hz$		55		dB	
			$f=1kHz$		55			
			$f=10kHz$		35			
Output Noise	V_n	$f=10Hz$ to $100kHz$		40		μV_{rms}		

Note1: The minimum input voltage ($V_{IN(MIN)}$) of the PAM3130 is determined by output voltage and dropout voltage. The minimum input voltage is defined as:

$$V_{IN(MIN)} = V_O + V_{drop}$$

Note 2: Output current is limited by P_D , maximum $I_O = P_D / (V_{IN(MAX)} - V_O)$.

Typical Performance Characteristics

$T_A=25^\circ\text{C}$, $C_{IN}=4.7\mu\text{F}$, $C_O=2.2\mu\text{F}$, unless otherwise noted.

1. Output Voltage vs Input Voltage

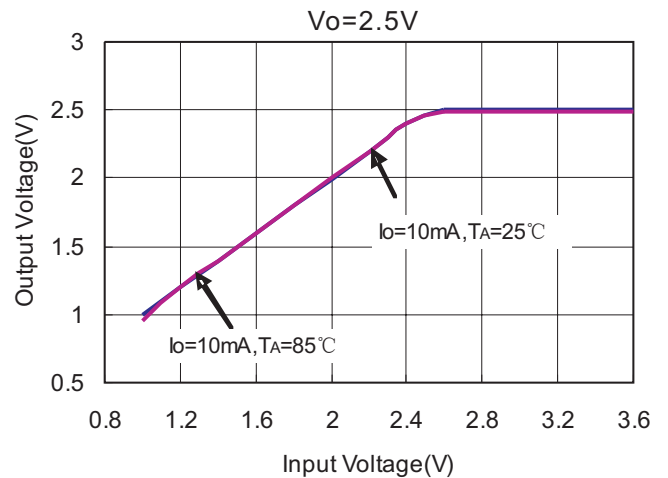
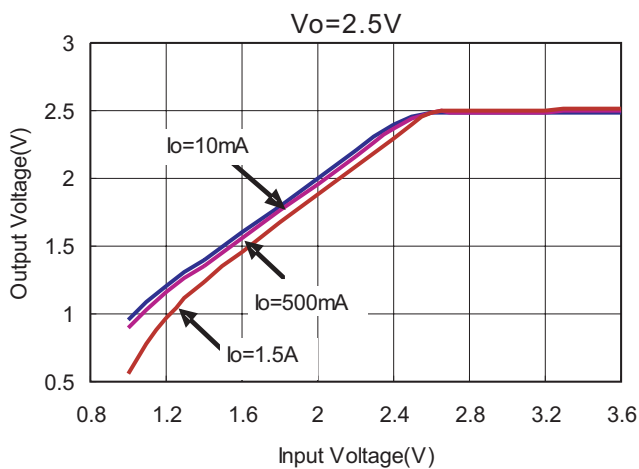
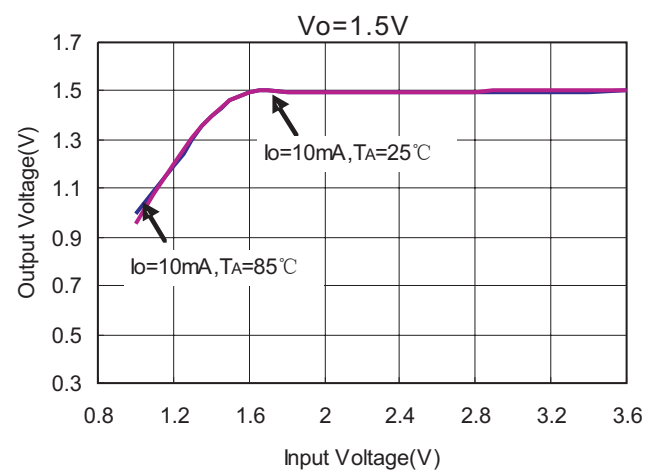
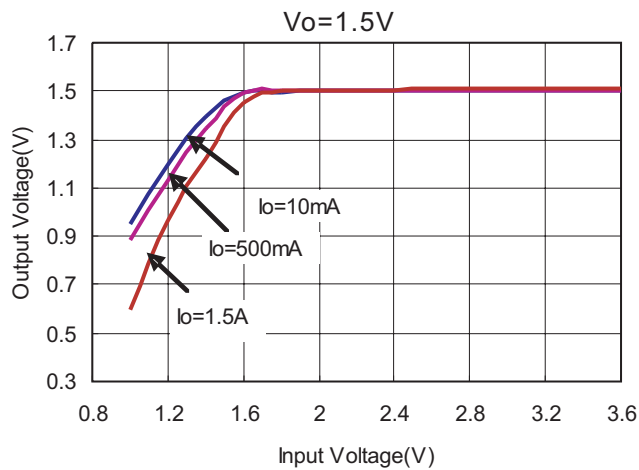
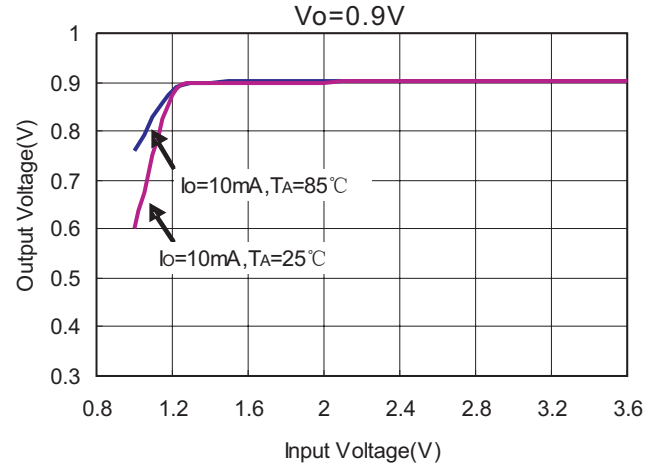
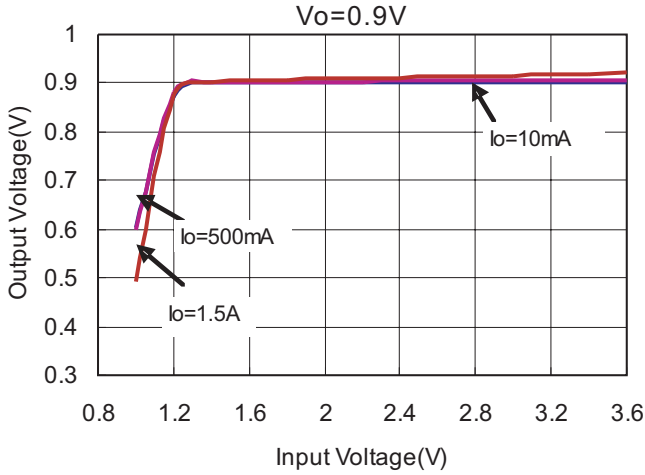

Typical Performance Characteristics (continued)

2. Output Voltage vs Output Current

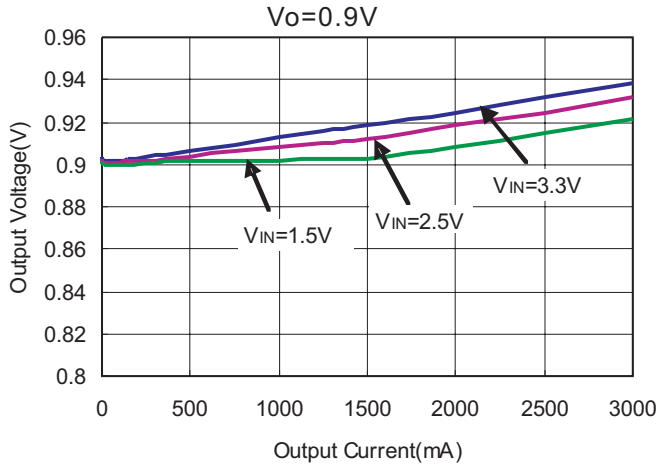

3. Output Voltage vs Temperature

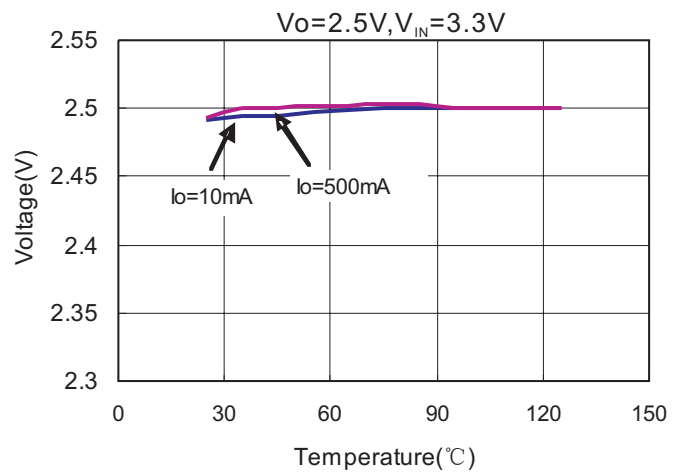
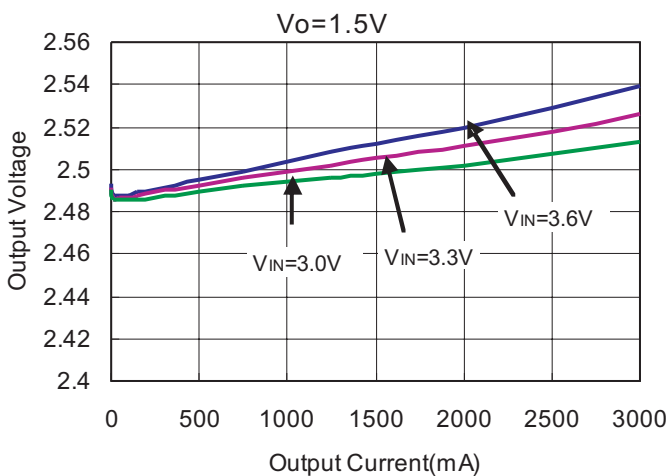
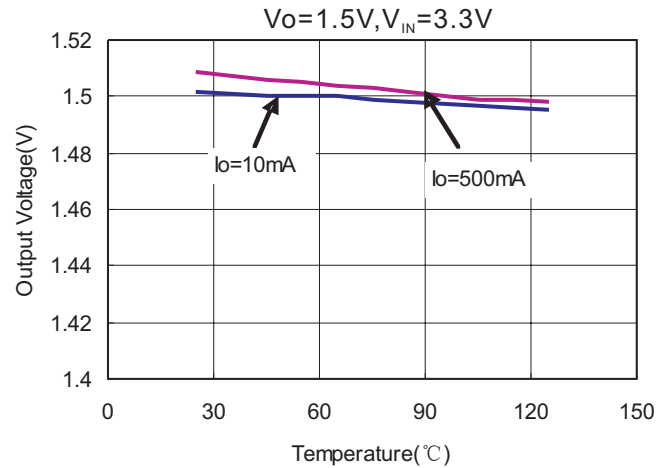
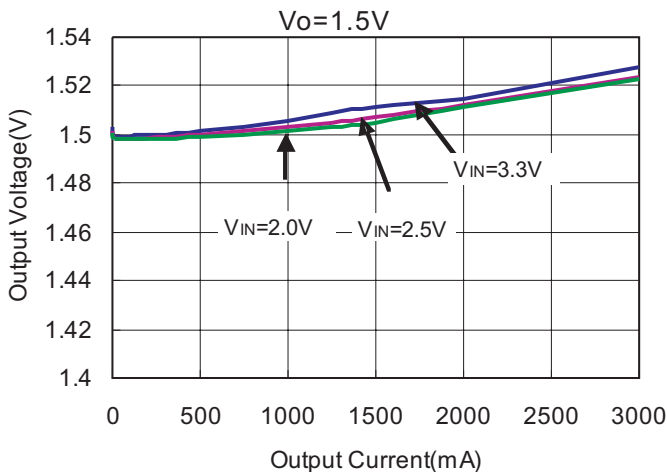
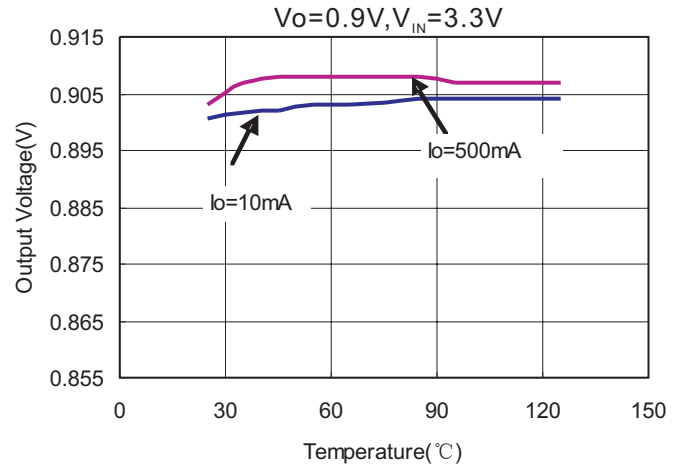

Typical Performance Characteristics (continued)

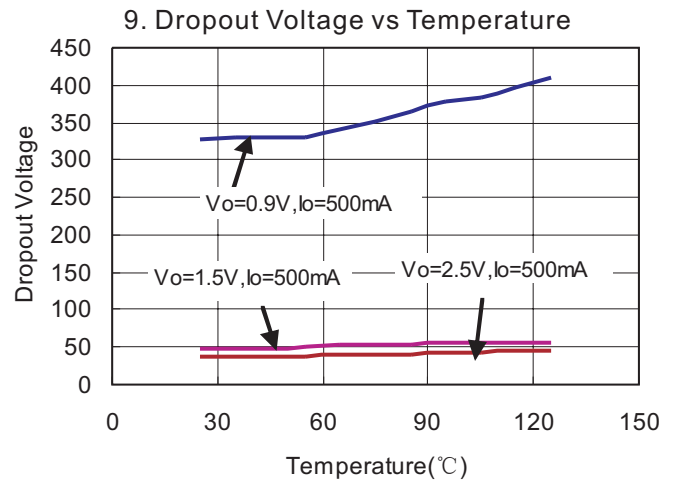
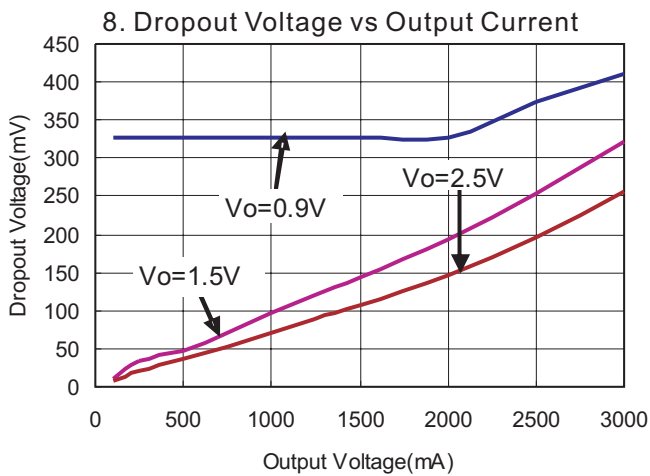
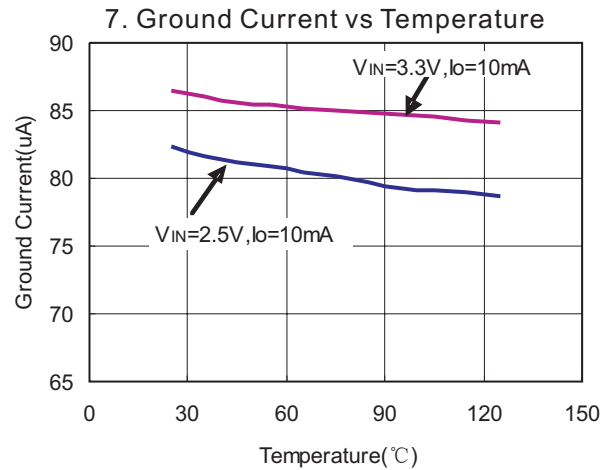
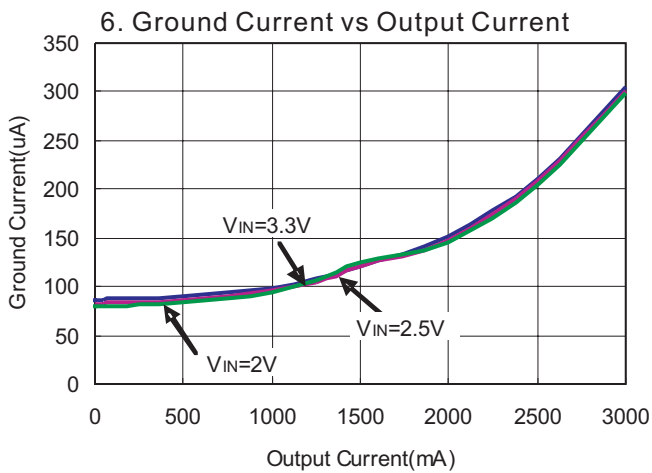
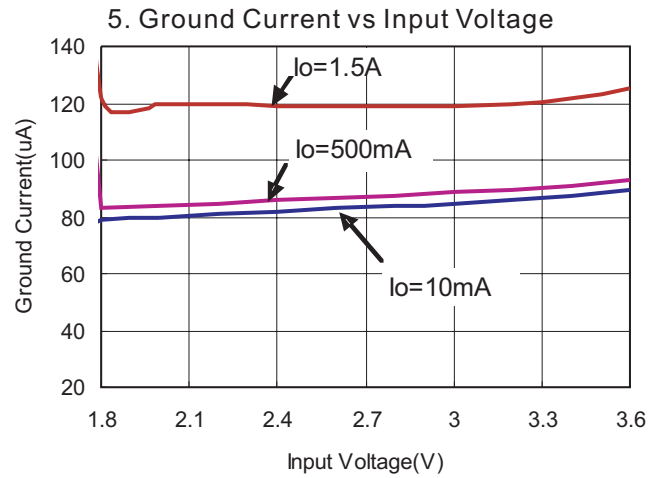
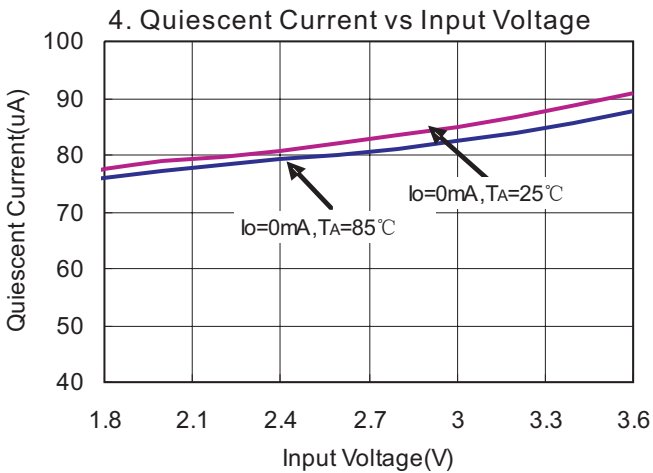

Typical Performance Characteristics (continued)

10. Ripple Rejection vs Frequency

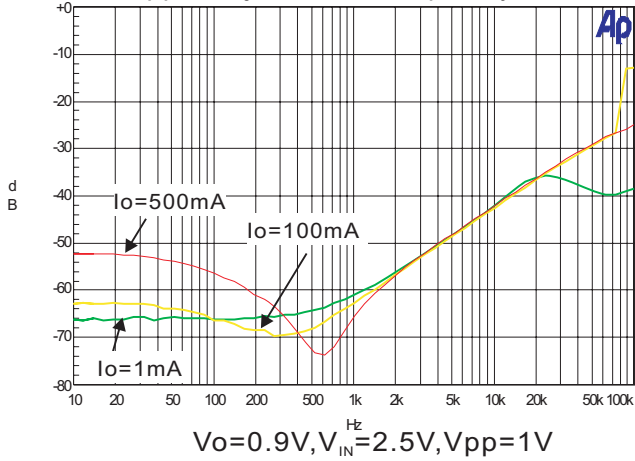

11. Load Transient Response

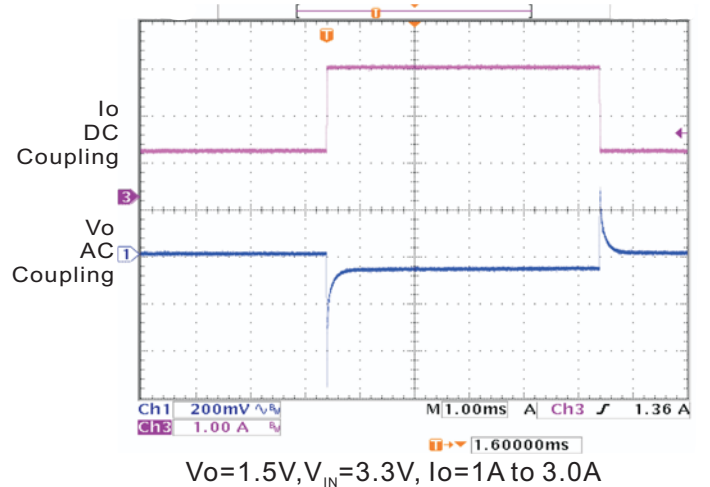
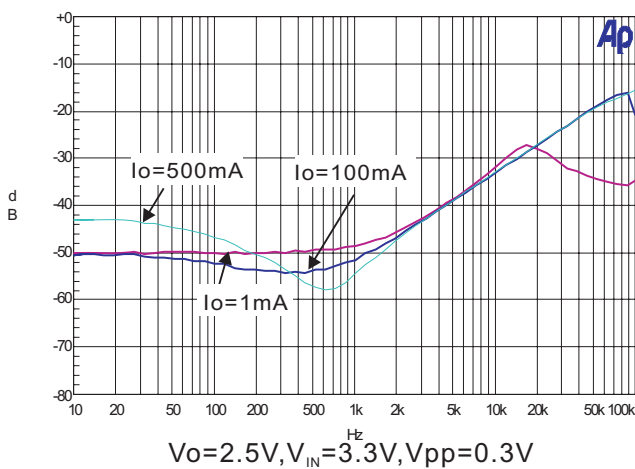
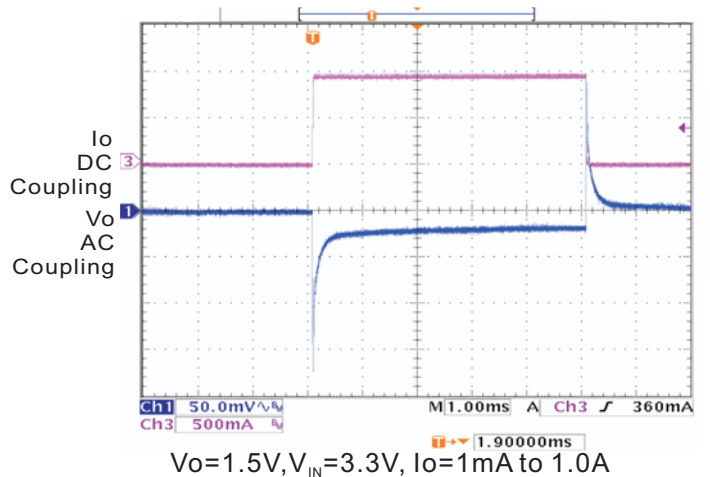
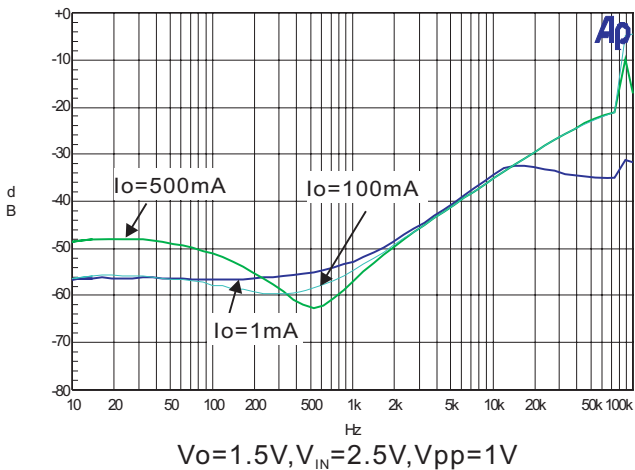
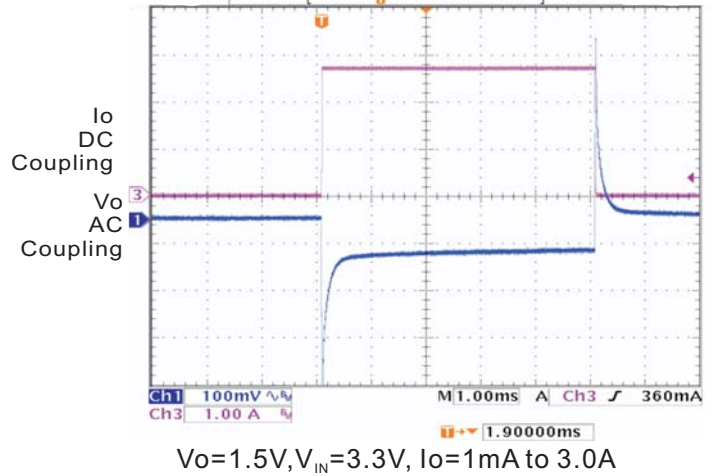

Typical Performance Characteristics (continued)

12. Line Transient Response

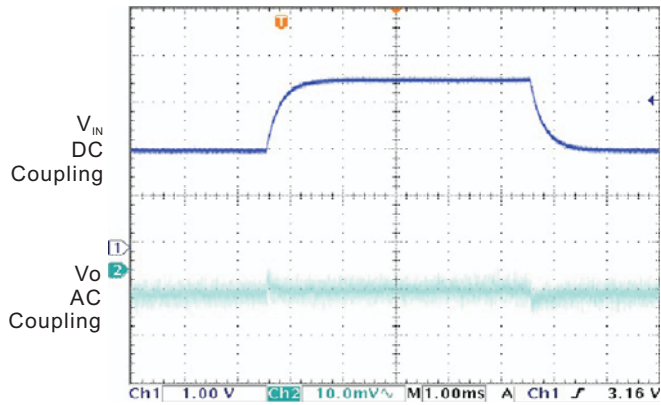

$V_o=1.5V, I_o=100mA, V_{IN}=2.0V \text{ to } 3.3V$

Application Information

The PAM3130 family of low-dropout (LDO) regulators have several features that allow them to apply to a wide range of applications. The family operates with very low input voltage (1.4V) and low dropout voltage (typically 300mV at full load), making it an efficient stand-alone power supply or post regulator for battery or switch mode power supplies. The 3A output current make the PAM3130 family suitable for powering many microprocessors and FPGA supplies. The PAM3130 family also has low output noise (typically 40µVRMS with 2.2µF output capacitor), making it ideal for use in telecom equipment.

External Capacitor Requirements

A 2.2µF or larger ceramic input bypass capacitor, connected between V_{IN} and GND and located close to the PAM3130, is required for stability. A 1.0µF minimum value capacitor from V_O to GND is also required. To improve transient response, noise rejection, and ripple rejection, an additional 10µF or larger, low ESR capacitor is recommended at the output. A higher value, low ESR output capacitor may be necessary if large, fast-rise-time load transients are anticipated and the device is located several inches from the power source, especially if the minimum input voltage of 1.4V is used.

Regulator Protection

The PAM3130 features internal current limiting, thermal protection and short circuit protection. During normal operation, the PAM3130 limits output current to about 4.5A. When current limiting engages, the output voltage scales back linearly until the over current condition ends. While current limiting is designed to prevent gross device failure, care should be taken not to exceed the power dissipation ratings of the package. If the temperature of the device exceeds 150°C, thermal-protection circuitry will shut down. Once the device has cooled down to approximately 50°C below the high temp trip point, regulator operation resumes. The short circuit current of the PAM3130 is about 1A when its output pin is shorted to ground.

Thermal Information

The amount of heat that an LDO linear regulator generates is:

$$P_D = (V_{IN} - V_O) I_O.$$

All integrated circuits have a maximum allowable junction temperature ($T_J \text{ max}$) above which normal operation is not assured. A system designer must design the operating environment so that the operating junction temperature (T_J) does not exceed the maximum junction temperature ($T_J \text{ max}$). The two main environmental variables that a designer can use to improve thermal performance are air flow and external heatsinks. The purpose of this information is to aid the designer in determining the proper operating environment for a linear regulator that is operating at a specific power level.

In general, the maximum expected power ($P_D(\text{max})$) consumed by a linear regulator is computed as:

$$P_{D\text{max}} = (V_{I(\text{avg})} - V_{O(\text{avg})}) \times I_{O(\text{avg})} + V_{I(\text{avg})} \times I_{(Q)} \quad (1)$$

Where:

- $V_{I(\text{avg})}$ is the average input voltage.
- $V_{O(\text{avg})}$ is the average output voltage.
- $I_{O(\text{avg})}$ is the average output current.
- $I_{(Q)}$ is the quiescent current.

For most LDO regulators, the quiescent current is insignificant compared to the average output current; therefore, the term $V_{I(\text{avg})} \times I_{(Q)}$ can be neglected. The operating junction temperature is computed by adding the ambient temperature (T_A) and the increase in temperature due to the regulator's power dissipation. The temperature rise is computed by multiplying the maximum expected power dissipation by the sum of the thermal resistances between the junction and the case ($R_{\theta JC}$), the case to heatsink ($R_{\theta CS}$), and the heatsink to ambient ($R_{\theta SA}$). Thermal resistances are measures of how effectively an object dissipates heat. Typically, the larger the device, the more surface area available for power dissipation so that the object's thermal resistance will be lower.

Ordering Information

PAM3130 X X X X

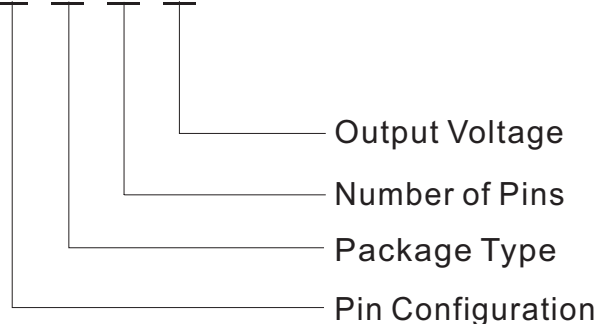

Pin Configuration	Package Type	Number of Pins	Output Voltage
A Type	F: TO-220	A: 3	090: 0.9V
1. VIN	M: TO-263	B: 5	100: 1.0V
2. GND	E: SOP-8	C: 8	120: 1.2V
3. VOUT			150: 1.5V
B Type			180: 1.8V
1. VIN			250: 2.5V
2. EN			280: 2.8V
3. GND			285: 2.85V
4. PWRGD			300: 3.0V
5. VOUT			330: 3.3V
C Type			
1. VIN			
2. EN			
3. GND			
4. SENSE			
5. VOUT			
D Type			
1. GND			
2. VIN			
3. EN			
4. GND			
5. PWRGD			
6. SENSE			
7. VOUT			
8. GND			



Ordering Information

Part Number	Output Voltage	Marking	Package Type	Shipping Packing
PAM3130AFA090	0.9V	P3130Z FATYW	TO-220	50 Units/Tube
PAM3130BMB090	0.9V	P3130Z FATYW	TO-263-5L	800 Units/Tape&Reel
PAM3130CMB090	0.9V	P3130Z FATYW	TO-263-5L	800 Units/Tape&Reel
PAM3130DEC090	0.9V	P3130Z FATYW	PSOP-8	2,500 Units/Tape&Reel
PAM3130AFA100	1.0V	P3130Y FATYW	TO-220	50 Units/Tube
PAM3130BMB100	1.0V	P3130Y FATYW	TO-263-5L	800 Units/Tape&Reel
PAM3130CMB100	1.0V	P3130Y FATYW	TO-263-5L	800 Units/Tape&Reel
PAM3130DEC100	1.0V	P3130Y FATYW	PSOP-8	2,500 Units/Tape&Reel
PAM3130AFA120	1.2V	P3130B FATYW	TO-220	50 Units/Tube
PAM3130BMB120	1.2V	P3130B FATYW	TO-263-5L	800 Units/Tape&Reel
PAM3130CMB120	1.2V	P3130B FATYW	TO-263-5L	800 Units/Tape&Reel
PAM3130DEC120	1.2V	P3130B FATYW	PSOP-8	2,500 Units/Tape&Reel
PAM3130AFA150	1.5V	P3130C FATYW	TO-220	50 Units/Tube
PAM3130BMB150	1.5V	P3130C FATYW	TO-263-5L	800 Units/Tape&Reel
PAM3130CMB150	1.5V	P3130C FATYW	TO-263-5L	800 Units/Tape&Reel
PAM3130DEC150	1.5V	P3130C FATYW	PSOP-8	2,500 Units/Tape&Reel
PAM3130AFA180	1.8V	P3130E FATYW	TO-220	50 Units/Tube
PAM3130BMB180	1.8V	P3130E FATYW	TO-263-5L	800 Units/Tape&Reel

(Cont'd on Next Page)



PAM3130

3A Low-Voltage Low-Dropout CMOS Regulator

Ordering Information (continued)

Part Number	Output Voltage	Marking	Package Type	Shipping Packing
PAM3130CMB180	1.8V	P3130E FATYW	TO-263-5L	800 Units/Tape&Reel
PAM3130DEC180	1.8V	P3130E FATYW	PSOP-8	2,500 Units/Tape&Reel
PAM3130AFA250	2.5V	P3130G FATYW	TO-220	50 Units/Tube
PAM3130BMB250	2.5V	P3130G FATYW	TO-263-5L	800 Units/Tape&Reel
PAM3130CMB250	2.5V	P3130G FATYW	TO-263-5L	800 Units/Tape&Reel
PAM3130DEC250	2.5V	P3130G FATYW	PSOP-8	2,500 Units/Tape&Reel
PAM3130AFA280	2.8V	P3130H FATYW	TO-220	50 Units/Tube
PAM3130BMB280	2.8V	P3130H FATYW	TO-263-5L	800 Units/Tape&Reel
PAM3130CMB280	2.8V	P3130H FATYW	TO-263-5L	800 Units/Tape&Reel
PAM3130DEC280	2.8V	P3130H FATYW	PSOP-8	2,500 Units/Tape&Reel
PAM3130AFA285	2.85V	P3130I FATYW	TO-220	50 Units/Tube
PAM3130BMB285	2.85V	P3130I FATYW	TO-263-5L	800 Units/Tape&Reel
PAM3130CMB285	2.85V	P3130I FATYW	TO-263-5L	800 Units/Tape&Reel
PAM3130DEC285	2.85V	P3130I FATYW	PSOP-8	2,500 Units/Tape&Reel
PAM3130AFA300	3.0V	P3130J FATYW	TO-220	50 Units/Tube
PAM3130BMB300	3.0V	P3130J FATYW	TO-263-5L	800 Units/Tape&Reel
PAM3130CMB300	3.0V	P3130J FATYW	TO-263-5L	800 Units/Tape&Reel
PAM3130DEC300	3.0V	P3130J FATYW	PSOP-8	2,500 Units/Tape&Reel

(Cont'd on Next Page)



PAM3130

3A Low-Voltage Low-Dropout CMOS Regulator

Ordering Information (continued)

Part Number	Output Voltage	Marking	Package Type	Shipping Packing
PAM3130AFA330	3.3V	P3130K FATYW	TO-220	50 Units/Tube
PAM3130BMB330	3.3V	P3130K FATYW	TO-263-5L	800 Units/Tape&Reel
PAM3130CMB330	3.3V	P3130K FATYW	TO-263-5L	800 Units/Tape&Reel
PAM3130DEC330	3.3V	P3130K FATYW	PSOP-8	2,500 Units/Tape&Reel

Outline Dimension

TO-263-5L

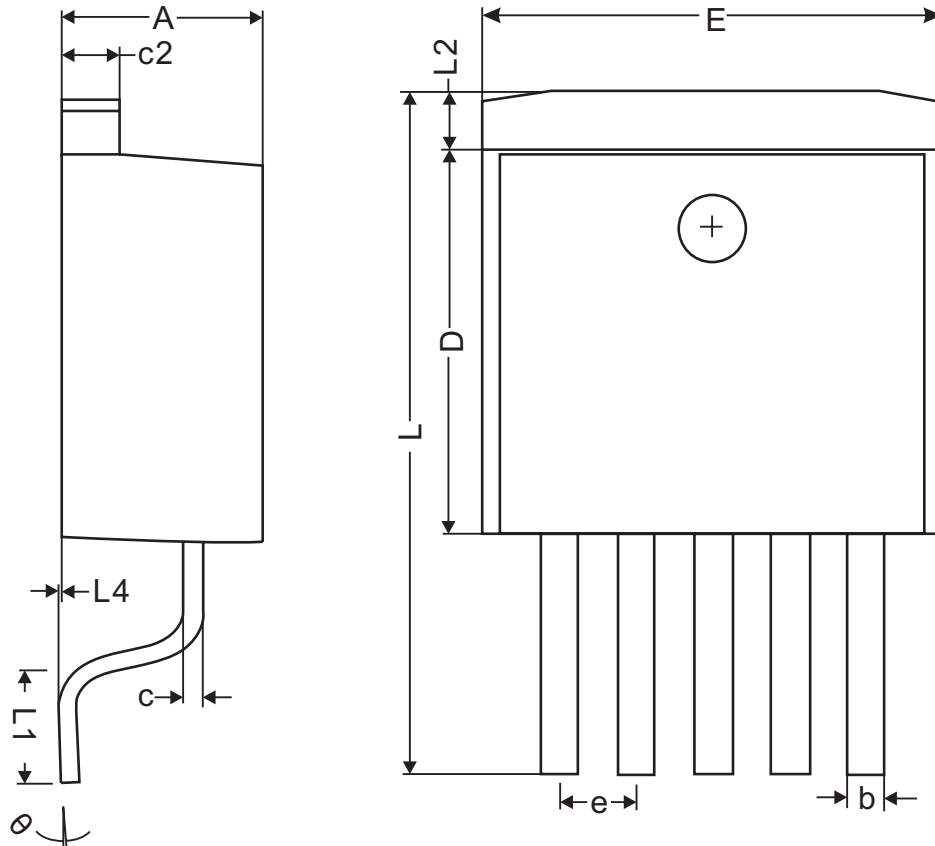

Dimensions(Millimeter)			
Symbol	MIN	NOM	MAX
A	4.40	4.60	4.80
b	0.66	0.78	0.91
L4	0.00	0.15	0.30
c	0.36	0.43	0.50
L3	1.50 REF.		
L1	2.29	2.54	2.79
E	9.80	10.1	10.4
c2	1.25	1.35	1.45
L2	1.27 REF.		
D	8.6	8.8	9.0
e	1.70 REF.		
L	14.6	15.2	15.8
θ	0°	4°	8°

Outline Dimension

TO-220

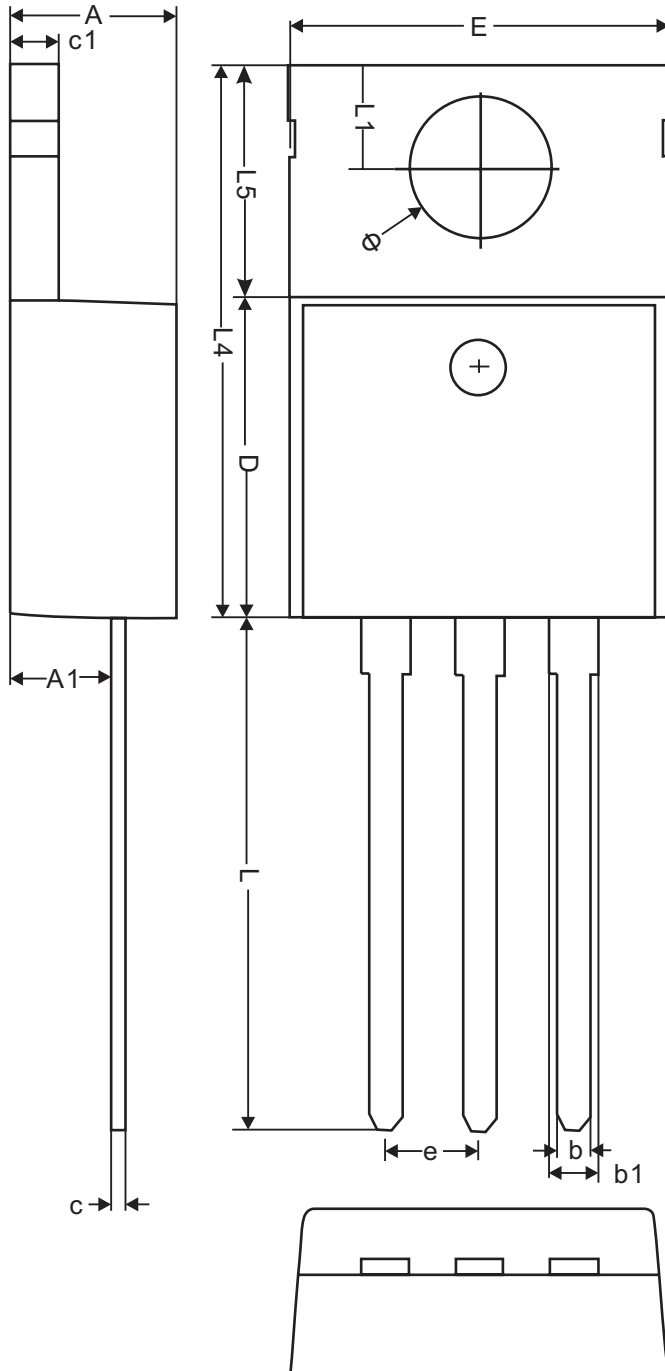

Dimensions(Millimeter)			
Symbol	MIN	NOM	MAX
A	4.40	4.60	4.80
b	0.76	0.88	1.0
D	8.60	8.80	9.00
c	0.36	0.43	0.50
E	9.80	10.1	10.4
L4	14.70	15.0	15.30
L5	6.20	6.40	6.60
c1	1.25	1.35	1.45
b1	1.17	1.32	1.47
L	13.25	13.75	14.25
e	2.54 REF.		
L1	2.60	2.74	2.89
ø	3.71	3.93	3.96
A1	2.60	2.70	2.80

Outline Dimension

PSOP-8

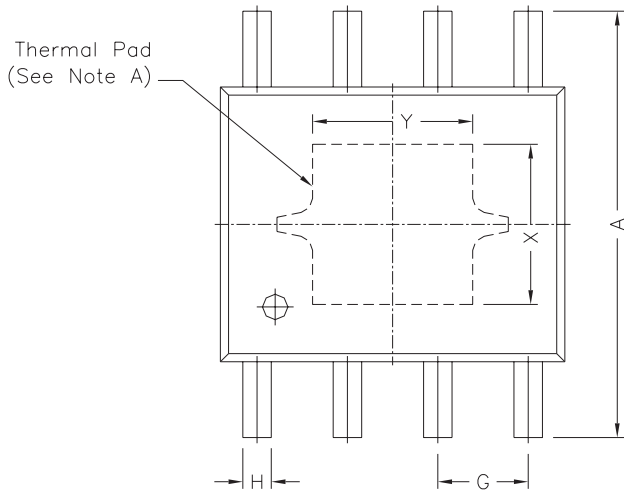

REF.	DIMENSIONS	
	Millimeters	
	Min.	Max.
A	5.80	6.20
B	4.80	5.00
C	3.80	4.00
D	0°	8°
E	0.40	0.90
F	0.19	0.25
M	0	0.15
H	0.35	0.49
L	1.35	1.75
G	1.27 TYP.	
Option1	X	2.28
	Y	2.28
Option2	X	2.41
	Y	3.30

