

Features

- Low-Dropout Regulator Supports Input Voltages Down to 1.4V
- Output Voltage Available in 0.9V, 1.0V, 1.2V, 1.5V, 1.8V, 2.5V, 2.8V, 2.85V, 3.0V, 3.3V
- Stable with a Ceramic Output Capacitor of 1.0 μ F or Higher
- Low Dropout Voltage: 150mV @1.5A
- Low Quiescent Current
- Over Temperature Shutdown
- Short Circuit Protection
- Low Temperature Coefficient
- Standard SOT-223, TO-252 and SOP-8 (Exposed Pad) Packages
- Pb-Free Package

Applications

- DSP, FPGA, and Microprocessor Power Supplies
- 1.2V Core Voltage for DSPs
- SATA Power Supply
- LCD TV/ Monitors
- Wireless Devices
- Communication Devices
- Portable Electronics
- Post Regulator for SMPS

General Description

The PAM3115 is a 1.5A CMOS LDO regulator that features a low quiescent current, ultra low input, output and dropout voltages, as well as over temperature shutdown. It is available in SOT-223, TO-252 and SOP-8 (exposed pad) packages. The fixed output voltage of the PAM3115 is set at the factory and trimmed to $\pm 2\%$. The PAM3115 is stable with a ceramic output capacitor of 1.0 μ F or higher.

This family of regulators can provide either a stand-alone power supply solution or act as a post regulator for switch mode power supplies. They are particularly well suitable for applications requiring low input and output voltages.

Typical Application

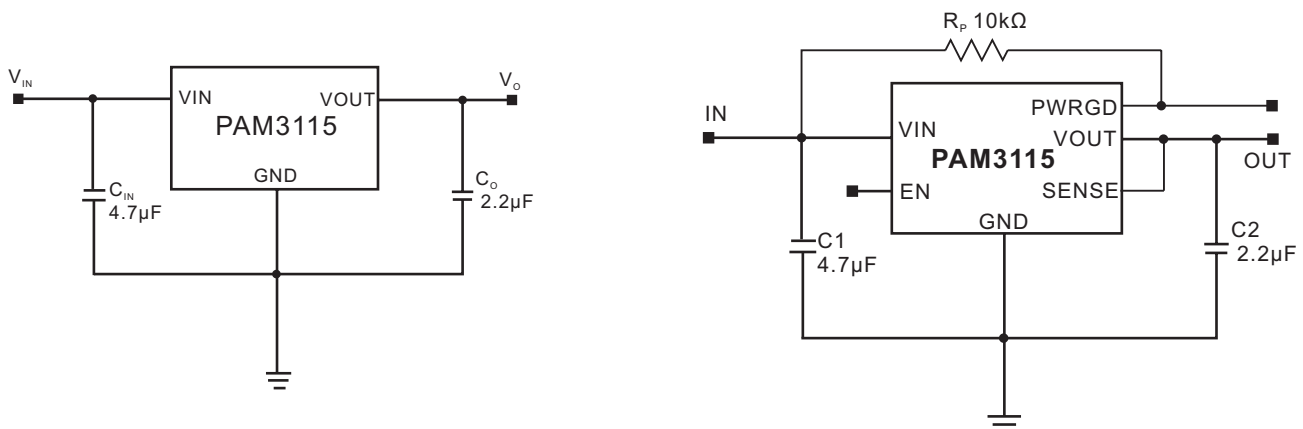

Block Diagram

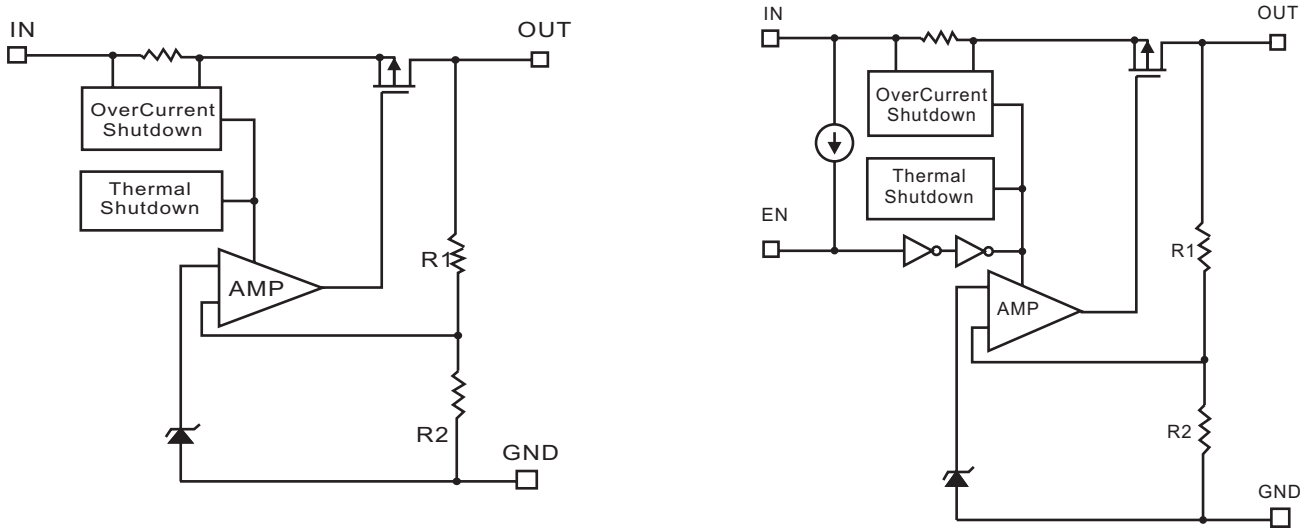

Pin Configuration & Marking Information

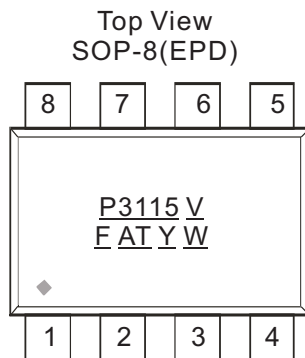

V: Voltage Code
 F: Internal Code
 A: Assembly Code
 T: Testing Code
 Y: Year
 W: Week

Pin Number	Name	Function
1	GND	Ground
2	VIN	Input
3	EN	Enable Pin
4	GND	Ground
5	PWRGD	Power Good
6	SENSE	Sense
7	VOUT	Output
8	GND	Ground

Pin Configuration & Marking Information (continued)

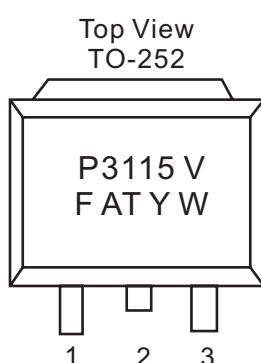
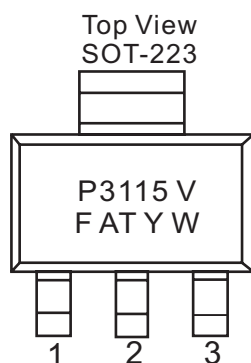

V: Voltage Code
F: Internal Code
A: Assembly Code
T: Testing Code
Y: Year
W: Week

Pin Number	Name	Function
1	V _{IN}	Input
2	GND	Ground
3	V _{OUT}	Output

Absolute Maximum Ratings

These are stress ratings only and functional operation is not implied. Exposure to absolute maximum ratings for prolonged time periods may affect device reliability. All voltages are with respect to ground.

Input Voltage.....	4.0V	Storage Temperature.....	-65°C to 150°C
Output Pin Voltage.....	-0.3V to V _{IN} +0.3V	Maximum Junction Temperature.....	150°C
Maximum Output Current.....	P _D /(V _{IN} -V _O)	Soldering Temperature.....	300°C, 5sec

Recommended Operating Conditions

Supply Voltage Range.....	1.4V to 3.6V	Operation Temperature Range.....	-40°C to 85°C
		Junction Temperature Range.....	-40°C to 125°C

Thermal Information

Parameter	Symbol	Package	Maximum	Unit
Thermal Resistance (Junction to Case)	θ_{JC}	SOT-223	7	°CW
		TO-252	7	
		SOP-8	11	
Thermal Resistance (Junction to Ambient)	θ_{JA}	SOT-223	160	
		TO-252	90	
		SOP-8	90	
Internal Power Dissipation	P _D	SOT-223	625	mW
		TO-252	1200	



Electrical Characteristic

$V_{IN} = V_O + 0.5V$, $T_A = 25^\circ C$, $C_{IN} = 4.7\mu F$, $C_O = 2.2\mu F$, unless otherwise noted.

Parameters	Symbol	Test Conditions	MIN	TYP	MAX	UNITS	
Input Voltage Range	V_{IN}		Note		3.6	V	
Output Voltage Accuracy	V_O	$I_O = 100mA$	-2		2	%	
Dropout Voltage	V_{DROP}	$I_O = 500mA$	$V_O = 0.9V$		330	500	mV
			$V_O = 1.0V$		220	400	
			$2.5V > V_O \geq 1.2V$		50	200	
			$V_O \geq 2.5V$		40	150	
		$I_O = 1.5A$	$V_O = 0.9V$		330	500	
			$V_O = 1.0V$		220	400	
			$2.5V > V_O \geq 1.2V$		150	350	
			$V_O \geq 2.5V$		120	300	
Short Circuit Current	I_{SC}	$V_O < 0.3V$		1.0		A	
Quiescent Current	I_Q	$I_O = 0mA$		90	150	μA	
Ground Pin Current	I_{GND}	$I_O = 1mA$ to $1.5A$			600	μA	
Line Regulation	LNR	$V_O \leq 2.5V, I_O = 10mA$ $V_{IN} = V_O + 0.5V$ to $V_O + 1.5V$		0.5	1	% / V	
		$V_O > 2.5V, I_O = 10mA$ $V_{IN} = 3.3V$ to $3.6V$					
Load Regulation	LDR	$I_O = 1mA$ to $1.5A$		0.5	2	% / A	
Over Temperature Shutdown	OTS			150		$^\circ C$	
Over Temperature Hysteresis	OTH			50		$^\circ C$	
Temperature Coefficient	TC			40		ppm / $^\circ C$	
Power Supply Ripple Rejection	PSRR	$I_O = 100mA$, $V_O = 1.5V$	$f = 100Hz$		55	dB	
			$f = 1KHz$		55		
			$f = 10KHz$		35		
Output Noise	V_n	$f = 10Hz$ to $100kHz$		40		μV_{rms}	

Note: The minimum input voltage ($V_{IN(MIN)}$) of the PAM3115 is determined by output voltage and dropout voltage. The minimum input voltage is defined as:

$$V_{IN(MIN)} = V_O + V_{drop}$$

Typical Performance Characteristics

$T_A=25^\circ\text{C}$, $C_{IN}=4.7\mu\text{A}$, $C_O=2.2\mu\text{F}$, unless otherwise noted.

1. Output Voltage vs Input Voltage

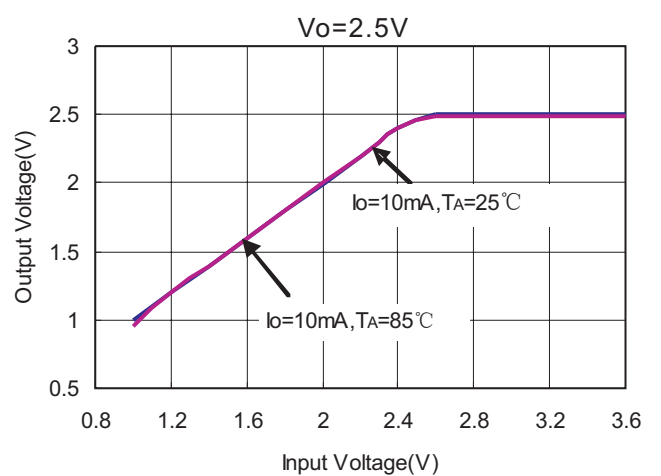
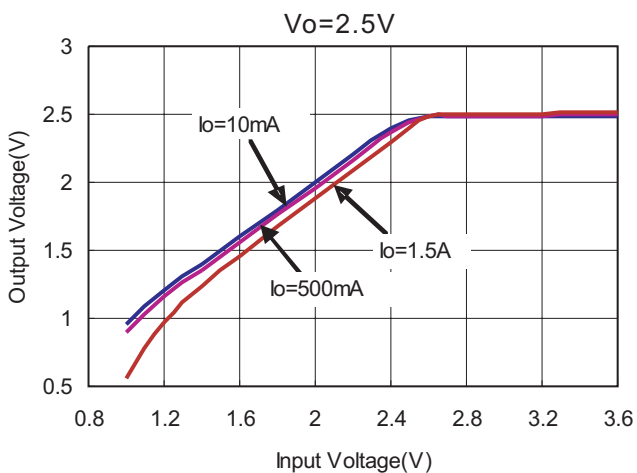
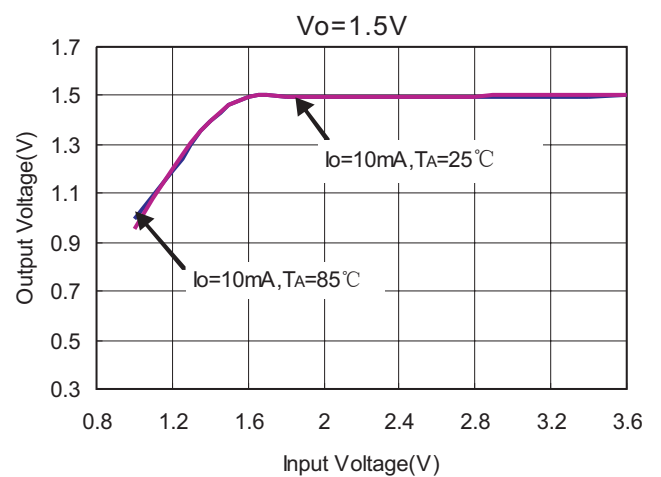
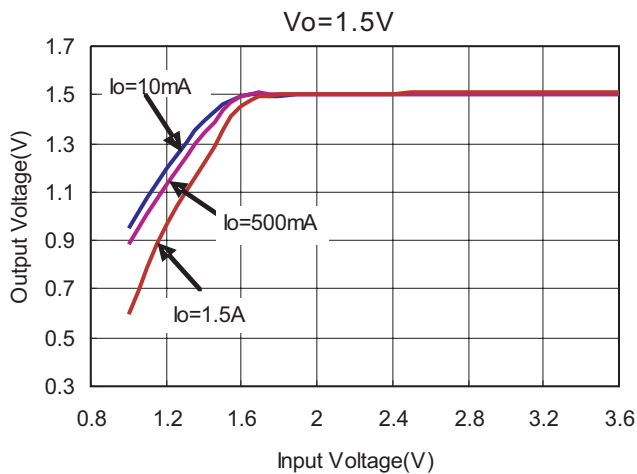
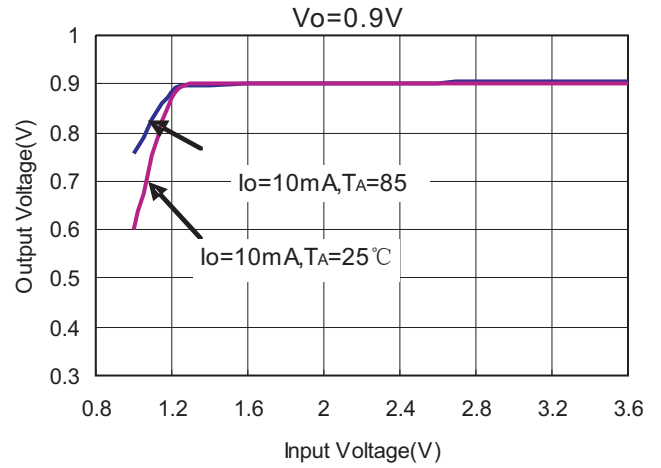
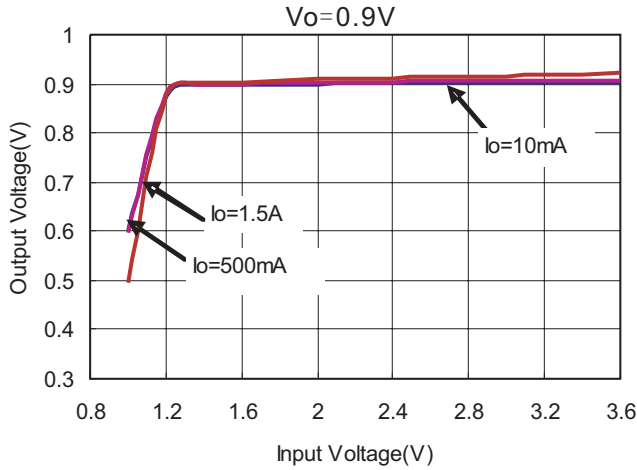

Typical Performance Characteristics (continued)

2. Output Voltage vs Output Current

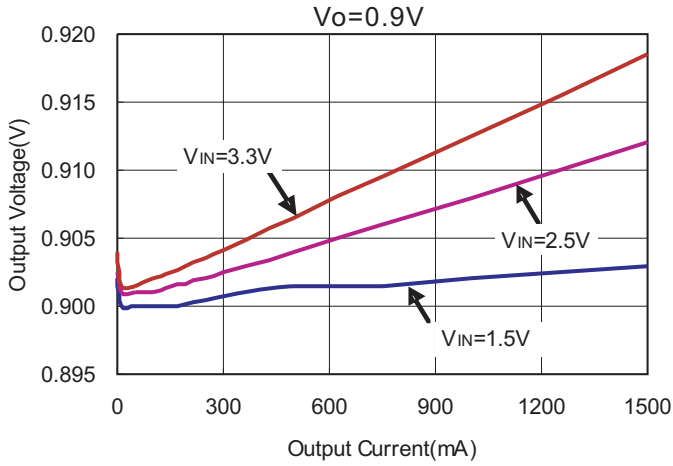

3. Output Voltage vs Temperature

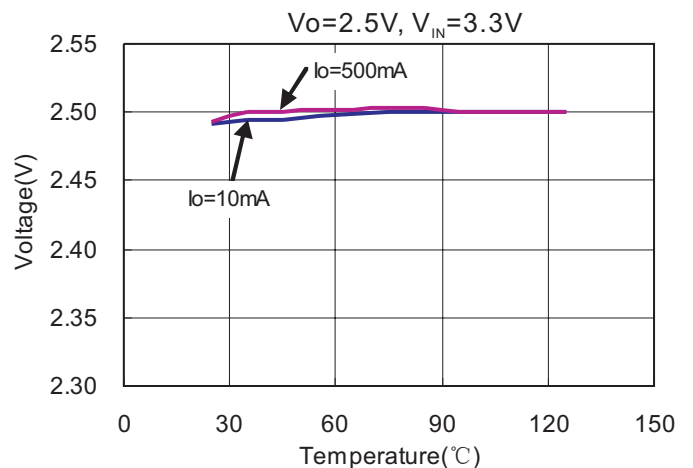
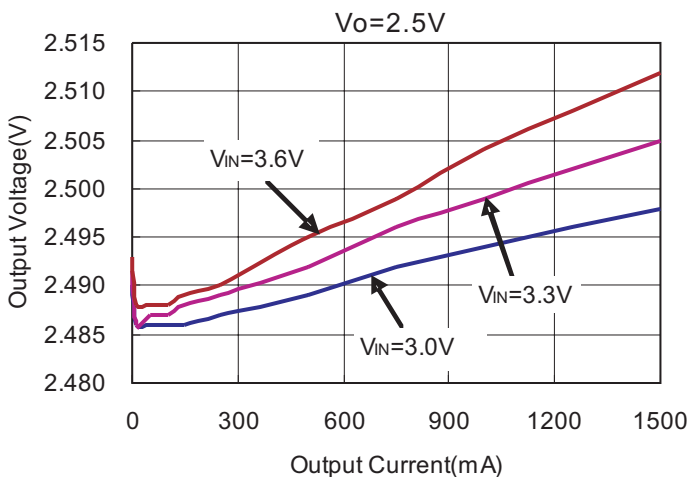
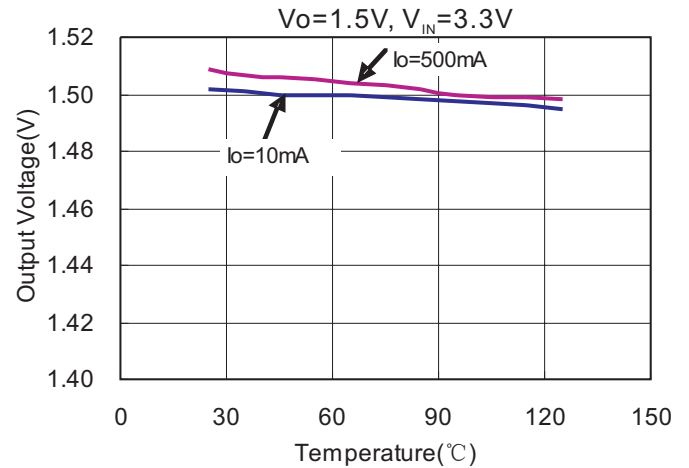
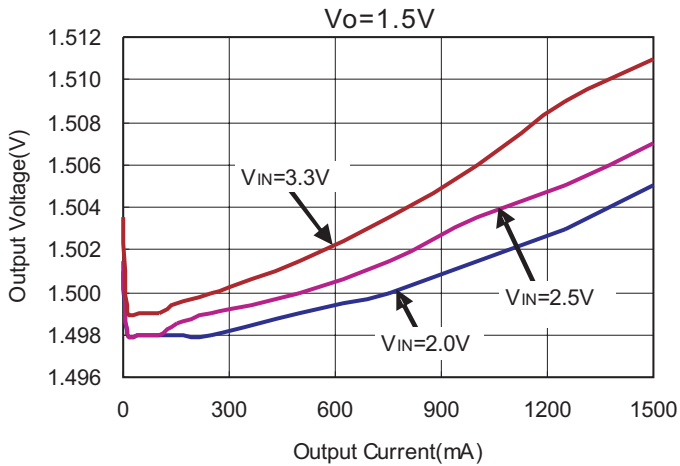
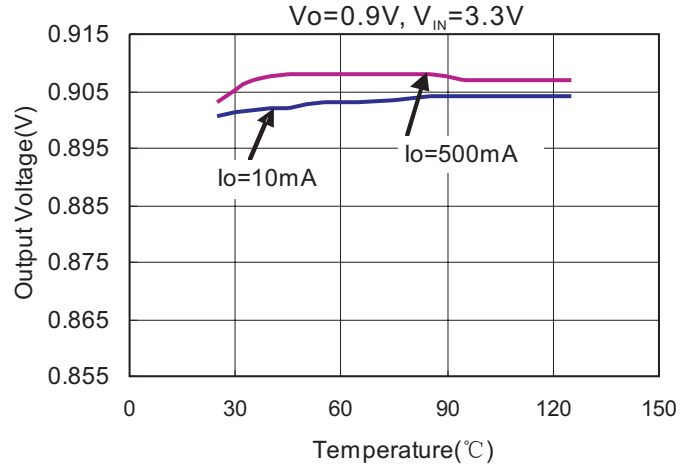

Typical Performance Characteristics (continued)

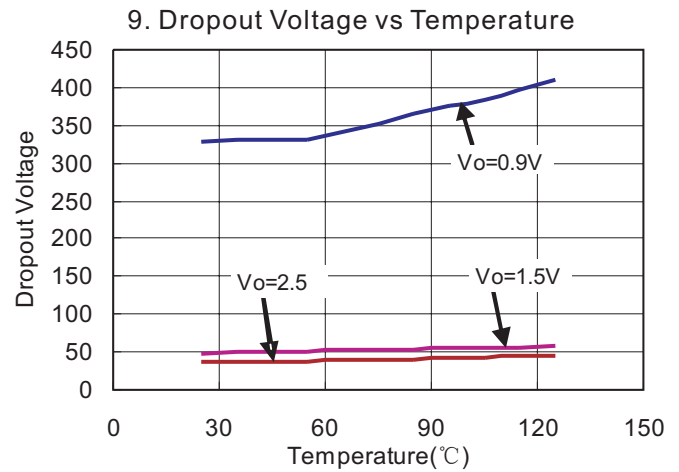
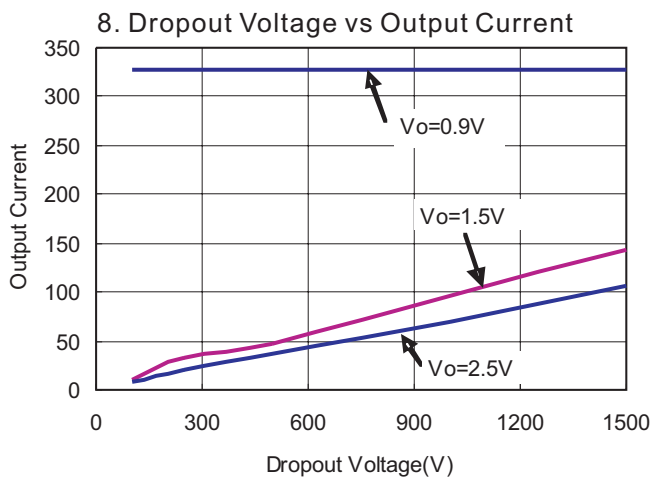
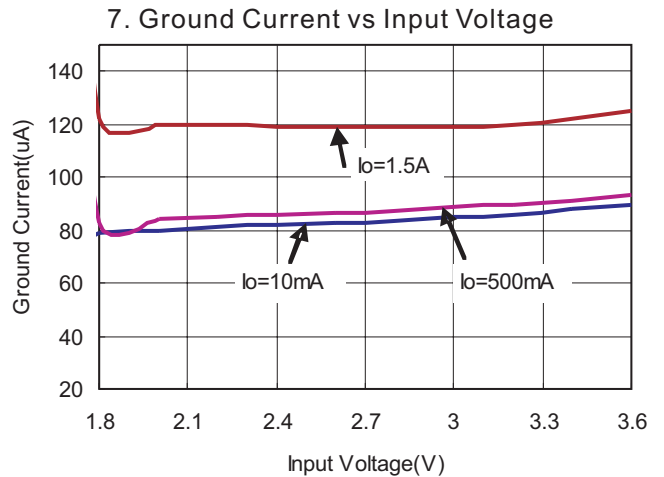
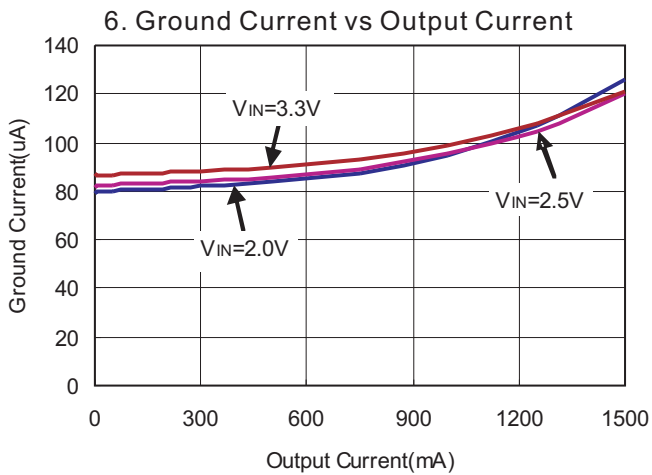
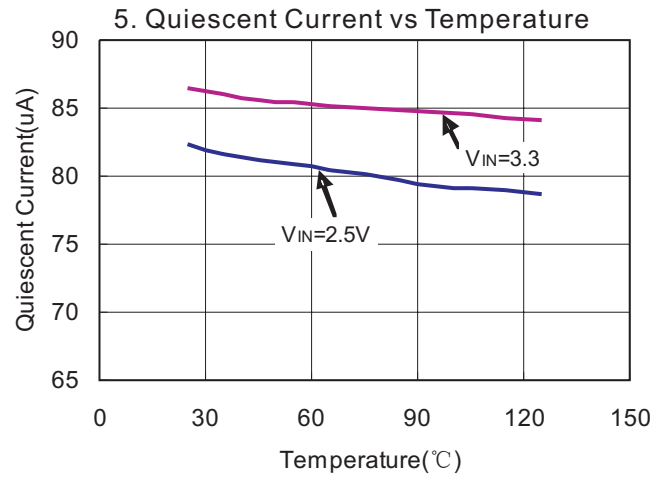
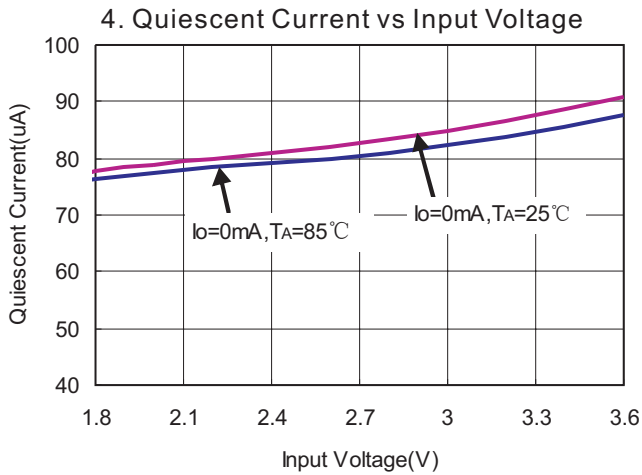

Typical Performance Characteristics (continued)

10. Ripple Rejection vs Frequency

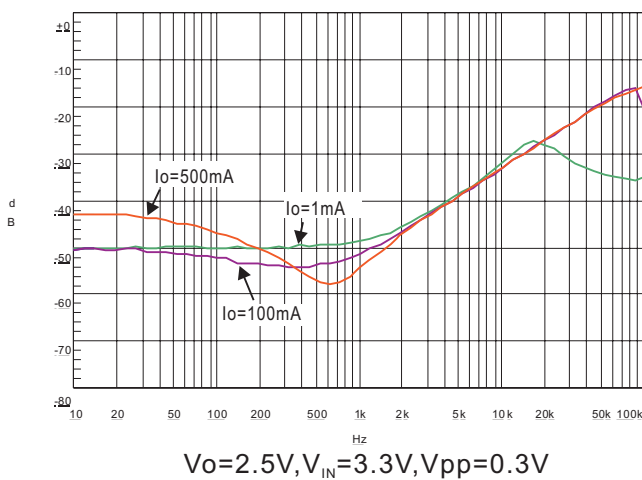
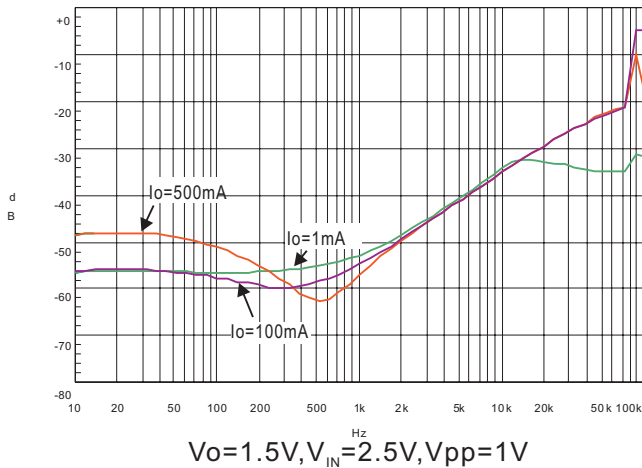
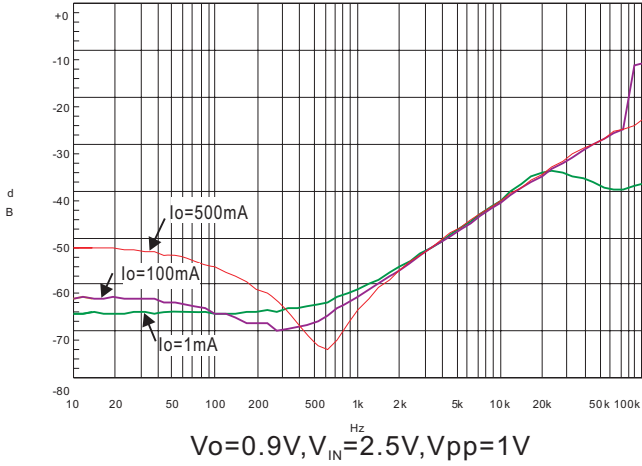

11. Load Transient Response

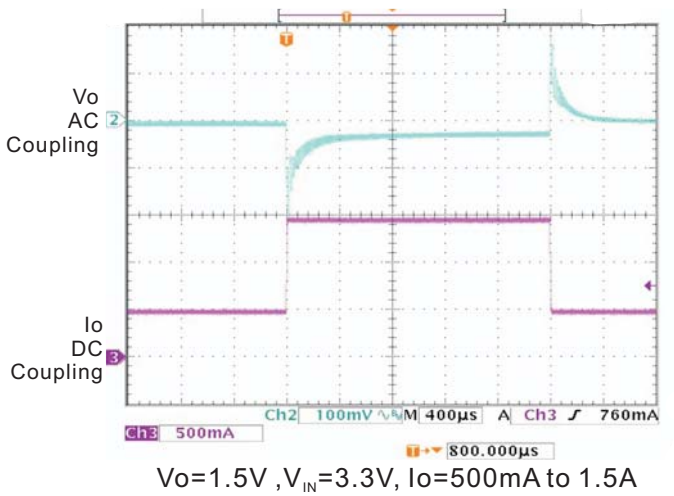
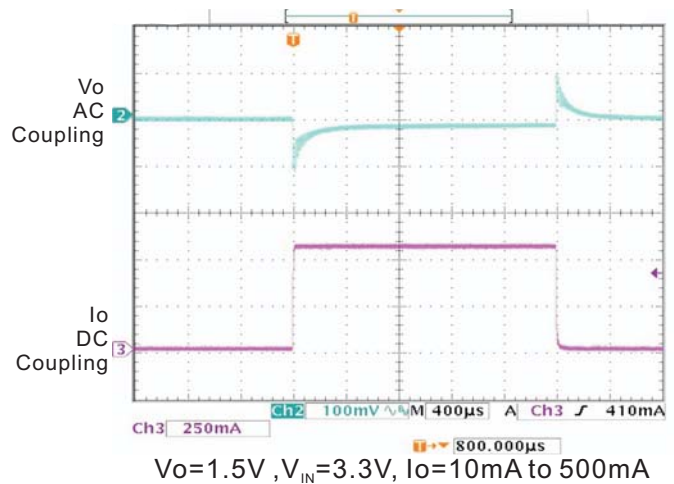
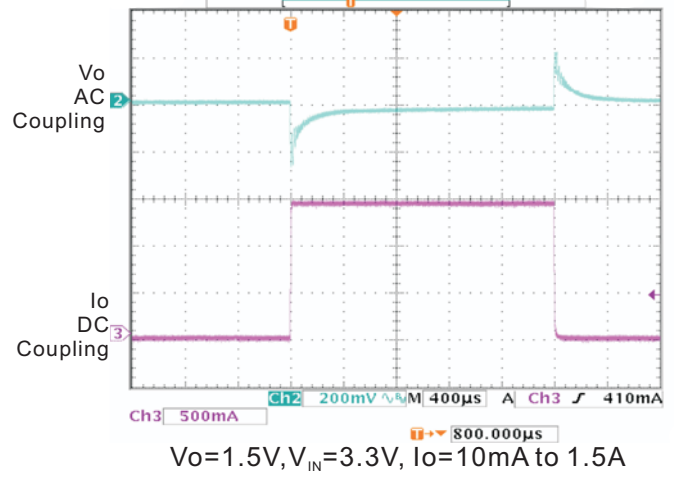

Typical Performance Characteristics (continued)

12. Line Transient Response

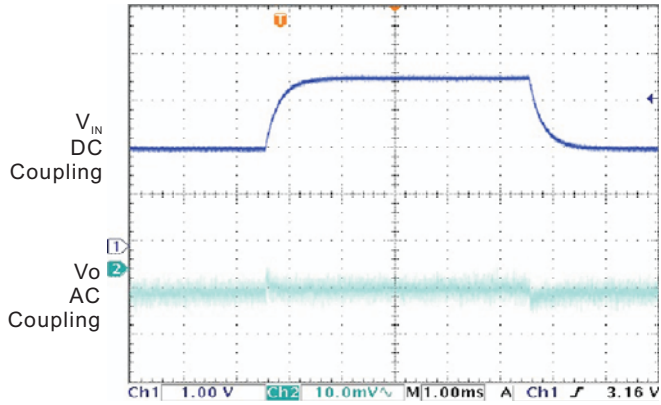

$V_O=1.5V, V_{IN}=2V \text{ to } 3.3V, I_O=1mA$

Application Information

The PAM3115 family of low-dropout (LDO) regulators have several features that allow them to apply to a wide range of applications. The family operates with very low input voltage (1.4V) and low dropout voltage (typically 150mV at full load), making it an efficient stand-alone power supply or post regulator for battery or switch mode power supplies. The 1.5A output current make the PAM3115 family suitable for powering many microprocessors and FPGA supplies. The PAM3115 family also has low output noise (typically 40µVRMS with 2.2µF output capacitor), making it ideal for use in telecom equipment.

External Capacitor Requirements

A 2.2µF or larger ceramic input bypass capacitor, connected between V_{IN} and GND and located close to the PAM3115, is required for stability. A 1.0µF minimum value capacitor from V_O to GND is also required. To improve transient response, noise rejection, and ripple rejection, an additional 10µF or larger, low ESR capacitor is recommended at the output. A higher-value, low ESR output capacitor may be necessary if large, fast-rise-time load transients are anticipated and the device is located several inches from the power source, especially if the minimum input voltage of 1.4 V is used.

Regulator Protection

The PAM3115 features internal current limiting, thermal protection and short circuit protection. During normal operation, the PAM3115 limits output current to about 3A. When current limiting engages, the output voltage scales back linearly until the over current condition ends. While current limiting is designed to prevent gross device failure, care should be taken not to exceed the power dissipation ratings of the package. If the temperature of the device exceeds 150°C, thermal-protection circuitry will shut down. Once the device has cooled down to approximately 50°C below the high temp trip point, regulator operation resumes. The short circuit current of the PAM3115 is about 1A when its output pin is shorted to ground.

Thermal Information

The amount of heat that an LDO linear regulator generates is:

$$P_D = (V_{IN} - V_O) I_O$$

All integrated circuits have a maximum allowable junction temperature ($T_J \text{ max}$) above which normal operation is not assured. A system designer must design the operating environment so that the operating junction temperature (T_J) does not exceed the maximum junction temperature ($T_J \text{ max}$). The two main environmental variables that a designer can use to improve thermal performance are air flow and external heatsinks. The purpose of this information is to aid the designer in determining the proper operating environment for a linear regulator that is operating at a specific power level.

In general, the maximum expected power ($P_D(\text{max})$) consumed by a linear regulator is computed as:

$$P_{D\text{MAX}} = (V_{I(\text{avg})} - V_{O(\text{avg})}) \times I_{O(\text{avg})} + V_{I(\text{avg})} \times I_{(Q)} \quad (1)$$

Where:

- $V_{I(\text{avg})}$ is the average input voltage.
- $V_{O(\text{avg})}$ is the average output voltage.
- $I_{O(\text{avg})}$ is the average output current.
- $I_{(Q)}$ is the quiescent current.

For most LDO regulators, the quiescent current is insignificant compared to the average output current; therefore, the term $V_{I(\text{avg})} \times I_{(Q)}$ can be neglected. The operating junction temperature is computed by adding the ambient temperature (T_A) and the increase in temperature due to the regulator's power dissipation. The temperature rise is computed by multiplying the maximum expected power dissipation by the sum of the thermal resistances between the junction and the case ($R_{\theta JC}$), the case to heatsink ($R_{\theta CS}$), and the heatsink to ambient ($R_{\theta SA}$). Thermal resistances are measures of how effectively an object dissipates heat. Typically, the larger the device, the more surface area available for power dissipation so that the object's thermal resistance will be lower.

Ordering Information

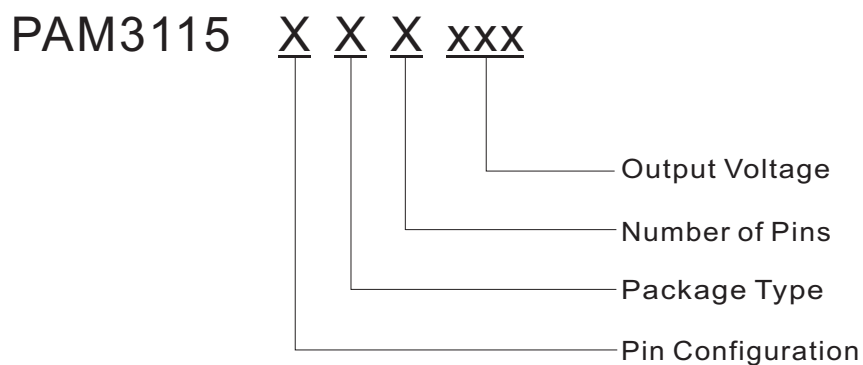

Pin Configuration	Package Type	Number of Pins	Output Voltage
A Type	B: SOT-223	A: 3	090: 0.9V
1. VIN	L: TO-252	C: 8	100: 1.0V
2. GND	E: SOP-8		120: 1.2V
3. VOUT			150: 1.5V
B Type			180: 1.8V
1. GND			250: 2.5V
2. VIN			280: 2.8V
3. EN			285: 2.85V
4. GND			300: 3.0V
5. PWRGD			330: 3.3V
6. SENSE			
7. VOUT			
8. GND			



PAM3115

1.5A Low-Voltage Low-Dropout CMOS Regulator

Ordering Information

Part Number	Output Voltage	Marking	Package Type	Standard Package
PAM3115ABA090	0.9V	P3115Z FATYW	SOT-223	2,500Units/Tape&Reel
PAM3115ALA090	0.9V	P3115Z FATYW	TO-252	2,500Units/Tape&Reel
PAM3115BEC090	0.9V	P3115Z FATYW	SOP-8	2,500Units/Tape&Reel
PAM3115ABA100	1.0V	P3115Y FATYW	SOT-223	2,500Units/Tape&Reel
PAM3115ALA100	1.0V	P3115Y FATYW	TO-252	2,500Units/Tape&Reel
PAM3115BEC100	1.0V	P3115Y FATYW	SOP-8	2,500Units/Tape&Reel
PAM3115ABA120	1.2V	P3115B FATYW	SOT-223	2,500Units/Tape&Reel
PAM3115ALA120	1.2V	P3115B FATYW	TO-252	2,500Units/Tape&Reel
PAM3115BEC120	1.2V	P3115B FATYW	SOP-8	2,500Units/Tape&Reel
PAM3115ABA150	1.5V	P3115C FATYW	SOT-223	2,500Units/Tape&Reel
PAM3115ALA150	1.5V	P3115C FATYW	TO-252	2,500Units/Tape&Reel
PAM3115BEC150	1.5V	P3115C FATYW	SOP-8	2,500Units/Tape&Reel
PAM3115ABA180	1.8V	P3115E FATYW	SOT-223	2,500Units/Tape&Reel
PAM3115ALA180	1.8V	P3115E FATYW	TO-252	2,500Units/Tape&Reel
PAM3115BEC180	1.8V	P3115E FATYW	SOP-8	2,500Units/Tape&Reel
PAM3115ABA250	2.5V	P3115G FATYW	SOT-223	2,500Units/Tape&Reel
PAM3115ALA250	2.5V	P3115G FATYW	TO-252	2,500Units/Tape&Reel
PAM3115BEC250	2.5V	P3115G FATYW	SOP-8	2,500Units/Tape&Reel

(To be continued)



Ordering Information

(continued)

Part Number	Output Voltage	Marking	Package Type	Standard Package
PAM3115ABA280	2.8V	P3115H FATYW	SOT-223	2,500Units/Tape&Reel
PAM3115ALA280	2.8V	P3115H FATYW	TO-252	2,500Units/Tape&Reel
PAM3115BEC280	2.8V	P3115H FATYW	SOP-8	2,500Units/Tape&Reel
PAM3115ABA285	2.85V	P3115I FATYW	SOT-223	2,500Units/Tape&Reel
PAM3115ALA285	2.85V	P3115I FATYW	TO-252	2,500Units/Tape&Reel
PAM3115BEC285	2.85V	P3115I FATYW	SOP-8	2,500Units/Tape&Reel
PAM3115ABA300	3.0V	P3115J FATYW	SOT-223	2,500Units/Tape&Reel
PAM3115ALA300	3.0V	P3115J FATYW	TO-252	2,500Units/Tape&Reel
PAM3115BEC300	3.0V	P3115J FATYW	SOP-8	2,500Units/Tape&Reel
PAM3115ABA330	3.3V	P3115K FATYW	SOT-223	2,500Units/Tape&Reel
PAM3115ALA330	3.3V	P3115K FATYW	TO-252	2,500Units/Tape&Reel
PAM3115BEC330	3.3V	P3115K FATYW	SOP-8	2,500Units/Tape&Reel

Outline Dimension

SOP-8

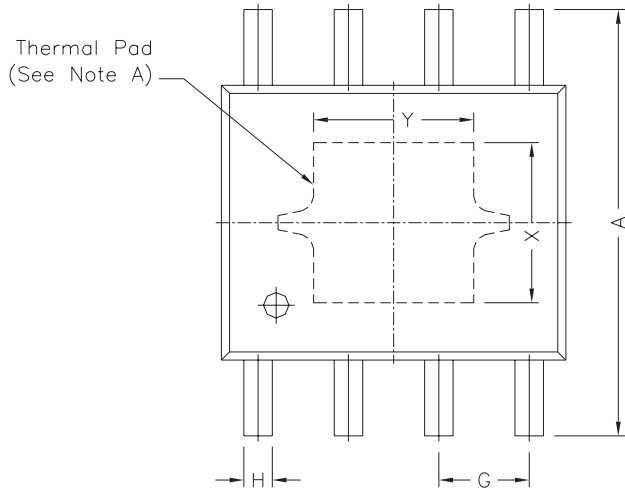

REF.	DIMENSIONS	
	Millimeters	
	Min.	Max.
A	5.80	6.20
B	4.80	5.00
C	3.80	4.00
D	0°	8°
E	0.40	0.90
F	0.19	0.25
M	0	0.15
H	0.35	0.49
L	1.35	1.75
G	1.27 TYP.	
Option1	X	2.28
	Y	2.28
Option2	X	2.41
	Y	3.30

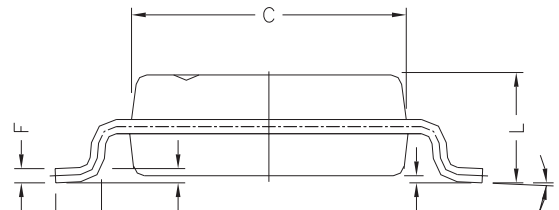
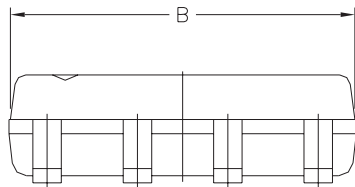

Outline Dimension

SOT-223

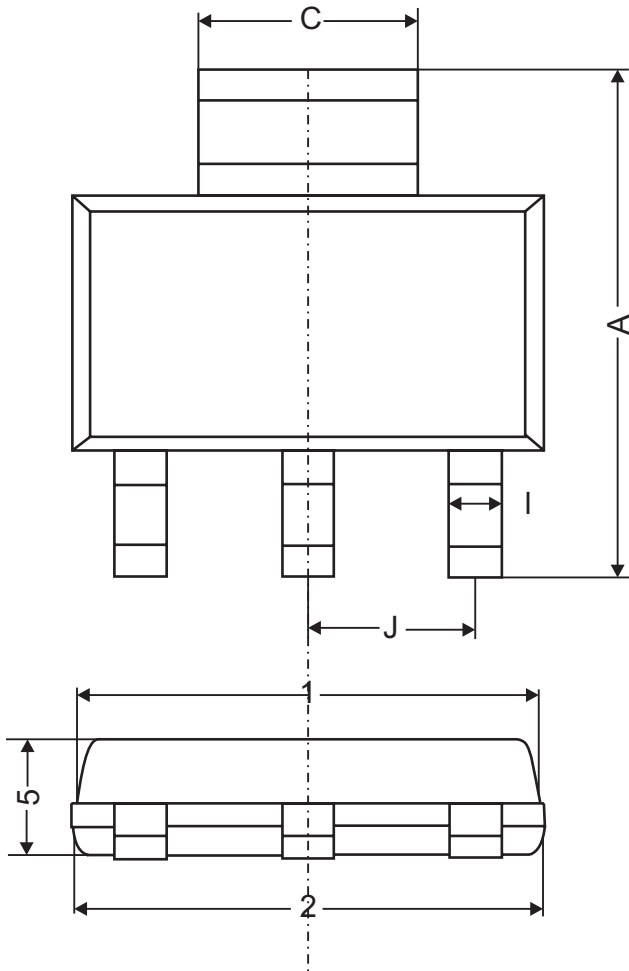

Dimensions(Millimeter)			
Symbol	MIN	NOM	MAX
A	6.70	7.00	7.30
C	2.90	3.00	3.10
D	0.02	0.06	0.10
E	0°	5°	10°
I	0.60	0.70	0.80
H	0.25	0.30	0.35
B	13° TYP		
J	2.30 REF.		
1	6.30	6.50	6.70
2	6.30	6.50	6.70
3	3.30	3.50	3.70
4	3.30	3.50	3.70
5	1.40	1.60	1.80

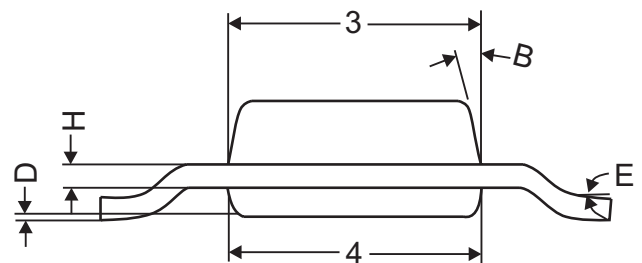

Outline Dimension

TO-252

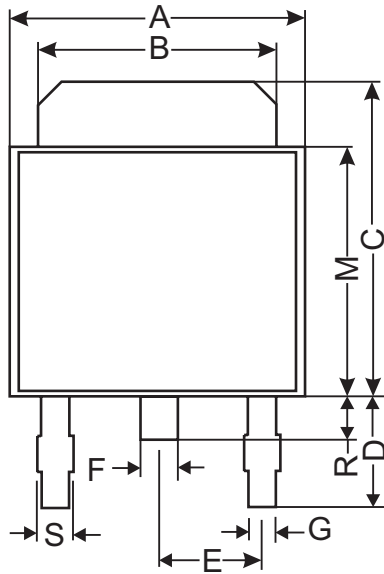

Dimensions(Millimeter)			
Symbol	MIN	NOM	MAX
A	6.40	6.60	6.80
B	5.20	5.35	5.50
C	6.80	7.00	7.20
D	2.20	2.50	2.80
E	2.30 REF.		
F	0.70	0.80	0.90
S	0.60	0.75	0.90
G	0.50	0.60	0.70
H	2.20	2.30	2.40
J	0.45	0.50	0.55
K	0	0.07	0.15
L	0.90	1.20	1.50
M	5.40	5.60	5.80
R	0.80	1.00	1.20

