

Features

- Low Dropout Voltage: 180mV@ 300mA ($V_o=3.3V$)
- Accuracy within $\pm 2\%$
- Quiescent Current: 65 μA Typ.
- High PSRR: 67dB@100Hz
- Excellent Line/Load Regulation
- Fast Response
- Current Limiting
- Short Circuit Protection
- Low Temperature Coefficient
- Shutdown Current: 0.5 μA
- Thermal Shutdown
- Space Saving Packages SOT23-5 and SC70-5
- Pb-Free Package

General Description

The PAM3103 is a positive, adjustable linear regulator. It features low quiescent current (65 μA Typ.) and low dropout voltage, making it ideal for battery powered applications. The output voltage is adjustable from 1.2V through 5V. Its high PSRR makes it useful in applications that require AC noise suppression on the input power supply. Space-saving SOT23-5 and SC70-5 packages are attractive for portable and handheld applications. It has both thermal shutdown and a current limit features to prevent device failure under extreme operating conditions. It is stable with an output capacitor of 2.2 μF or greater.

Applications

- Cordless Phone
- Cellular Phone
- Bluetooth Earphone
- Digital Camera
- Portable Electronics
- WLAN
- MP3 Player

Typical Application

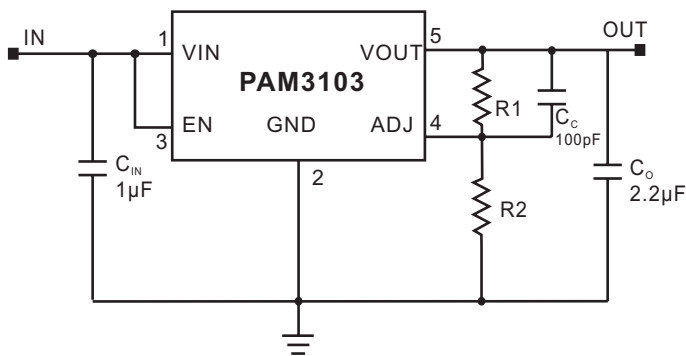

$$V_o = V_{REF} * (R1 + R2) / R2$$

Block Diagram

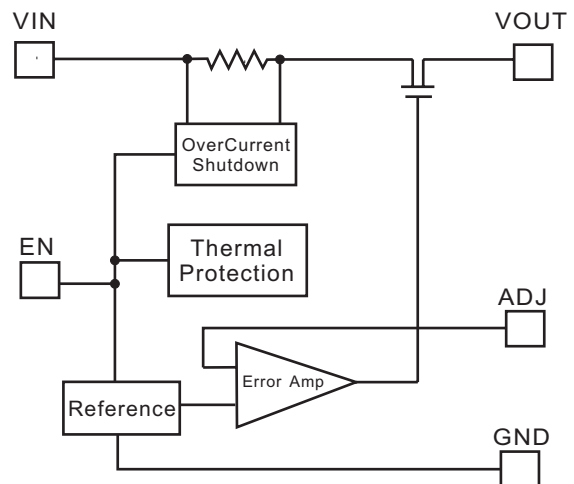

Pin Configuration & Marking Information

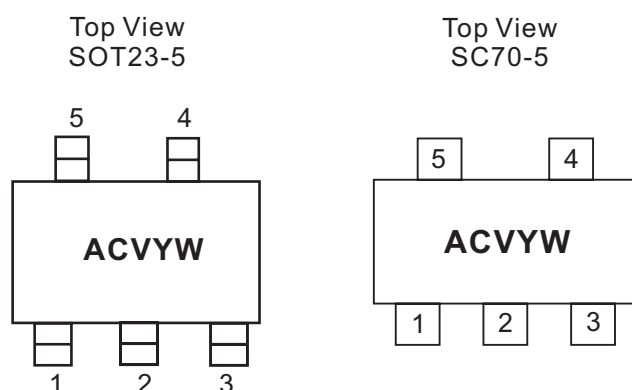

AC: Product Code of PAM3101
 V: Voltage Code
 Y: Year
 W: Week

Pin Number	Name	Function
1	VIN	Input
2	GND	Ground
3	EN	Chip Enable (Active High)
4	ADJ	Adjustable Pin
5	VOUT	Output

Absolute Maximum Ratings

These are stress ratings only and functional operation is not implied. Exposure to absolute maximum ratings for prolonged time periods may affect device reliability. All voltages are with respect to ground.

Input Voltage.....6.0V	Lead Soldering Temperature(5sec).....300°C
Output Current.....300mA	Storage Temperature.....-65°C to 150°C
Output Pin Voltage.....GND-0.3 to $V_{IN}+0.3V$	

Recommended Operating Conditions

Max. Supply Voltage5.5V	Operation Temperature.....-40°C to 85°C
Junction Temperature.....-40°C to 125°C	

Thermal Information

Parameter	Symbol	Package	Maximum	Unit
Thermal Resistance (Junction to Case)	θ_{JC}	SOT23-5	130	°C/W
		SC70-5	TBD	
Thermal Resistance (Junction to Ambient)	θ_{JA}	SOT23-5	250	°C/W
		SC70-5	300	
Internal Power Dissipation	P_D	SOT23-5	400	mW
		SC70-5	300	



Electrical Characteristic

$T_A=25^{\circ}\text{C}$, $V_{IN}=4\text{V}$, $V_O=3\text{V}$, $C_{IN}=1\mu\text{F}$, $C_O=2.2\mu\text{F}$, unless otherwise noted.

PARAMETER	SYMBOL	Test Conditions	MIN	TYP	MAX	UNITS	
Input Voltage	V_{IN}		Note 1		5.5	V	
Output Voltage	V_O		1.2		5	V	
Reference Voltage	V_{REF}			1.235		V	
Output Voltage Accuracy	V_O	$I_O=1\text{mA}$	-2		2	%	
Output Current	I_O		300		Note 2	mA	
Short Circuit Current	I_{SC}	$V_O=0\text{V}$		150		mA	
Dropout Voltage	V_{drop}	$I_O=300\text{mA}$	$2.5\text{V}\leq V_O<3.3\text{V}$		370	450	mV
			$V_O\geq 3.3\text{V}$		180	230	
Ground Current	I_{GND}	$I_O=1\text{mA}$ to 300mA		70	90	μA	
Quiescent Current	I_Q	$I_O=0\text{mA}$		65	90	μA	
Line Regulation	LNR	$I_O=1\text{mA}$, $V_{IN}=3\text{V}$ to 5V	-0.4	0.2	0.4	%/V	
Load Regulation	LDR	$I_O=1\text{mA}$ to 300mA	-1	0.2	1	%	
Temperature Coefficient	T_c			40		ppm/ $^{\circ}\text{C}$	
Over Temperature Shutdown	OTS	$I_O=1\text{mA}$		150		$^{\circ}\text{C}$	
Over Temperature Hysteresis	OTH	$I_O=1\text{mA}$		30		$^{\circ}\text{C}$	
Power Supply Ripple Rejection	PSRR	$I_O=100\text{mA}$, $V_O=1.2\text{V}$	$f=100\text{Hz}$		67		dB
			$f=1\text{kHz}$		65		dB
			$f=10\text{kHz}$		42		dB
Output Noise	V_n	$f=10\text{Hz}$ to 100kHz		50		μVrms	
EN Input High Threshold	V_{IH}	$V_{IN}=2.5\text{V}$ to 5V	1.5			V	
EN Input Low Threshold	V_{IL}	$V_{IN}=2.5\text{V}$ to 5V			0.3	V	
Shutdown Current	I_{SD}	$V_{EN}=0\text{V}$		0.01	1	μA	

Note 1: The minimum input voltage ($V_{IN(MIN)}$) of the PAM3103 is determined by output voltage and dropout voltage. The minimum input voltage is defined as:

$$V_{IN(MIN)} = V_O + V_{drop}$$

Note 2: Output current is limited by P_D , maximum $I_O = P_D / (V_{IN(MAX)} - V_O)$.

Typical Performance Characteristics

$T_A=25^\circ\text{C}$, $V_O=1.2\text{V}$, $C_{IN}=1\mu\text{F}$, $C_O=2.2\mu\text{F}$, unless otherwise noted.

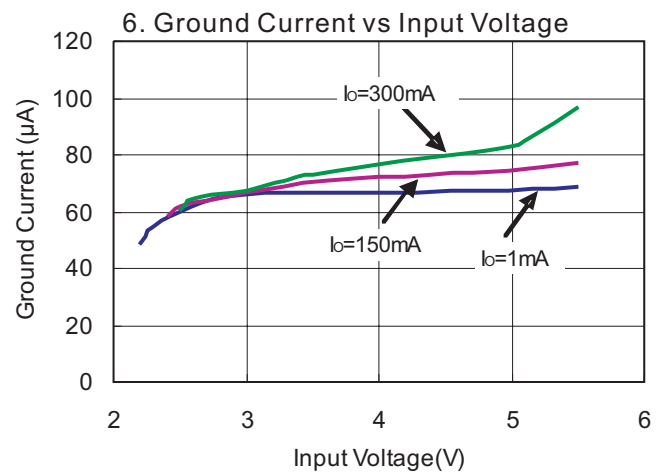
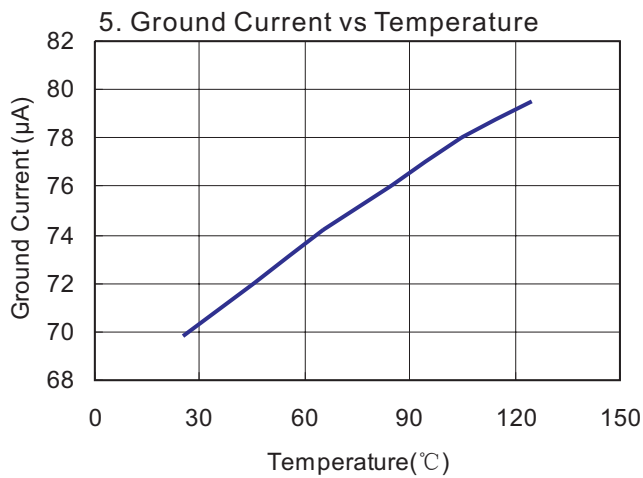
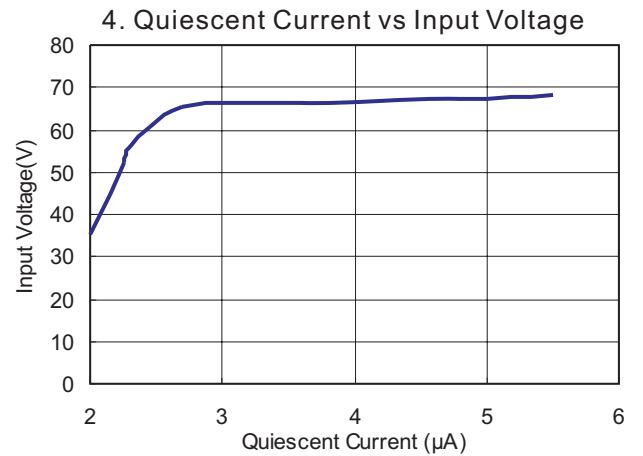
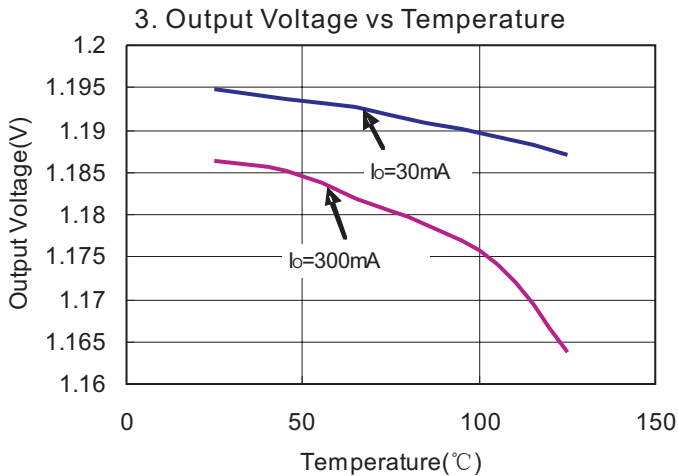
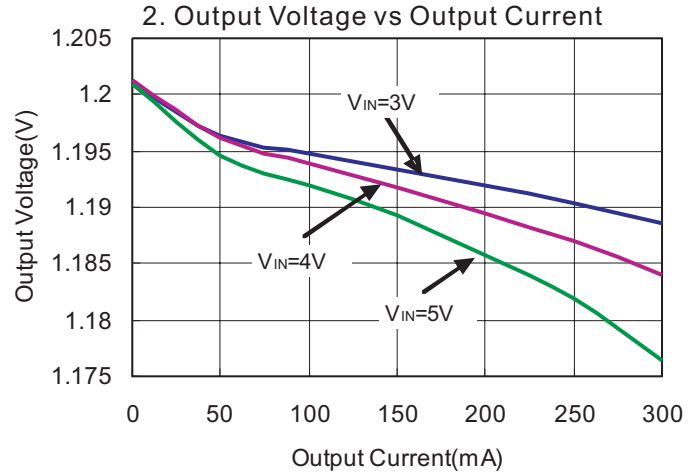
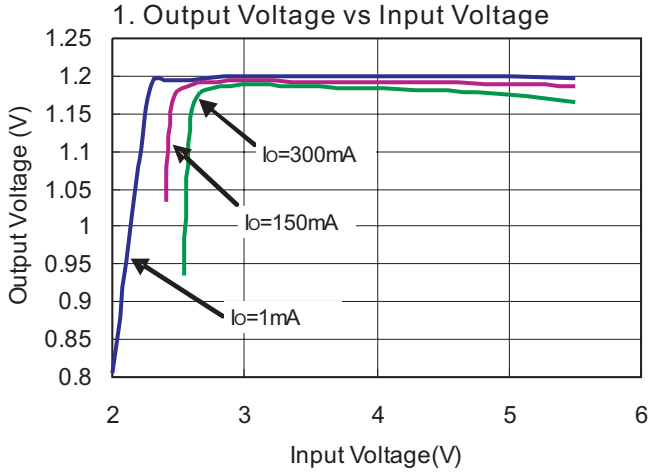

Typical Performance Characteristics (continued)

7. Load Regulation Transient Response

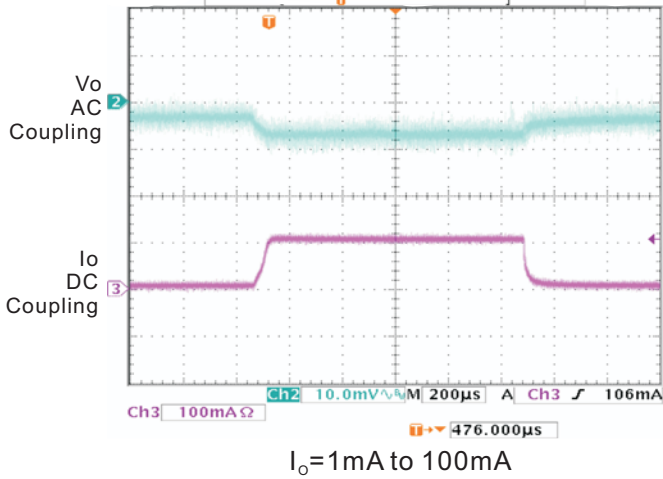

8. Line Regulation Transient Response

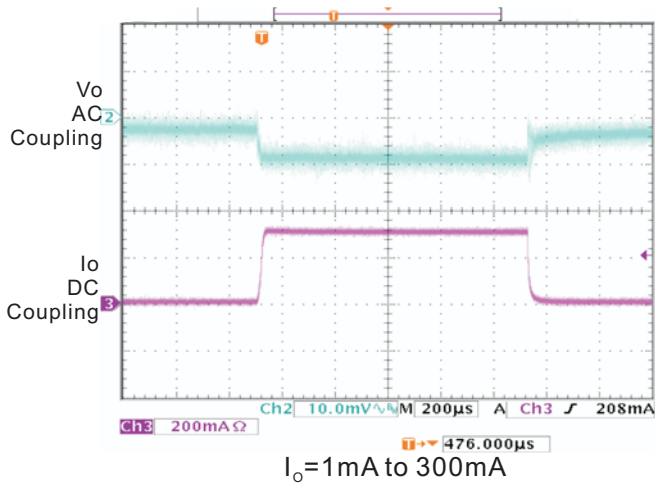
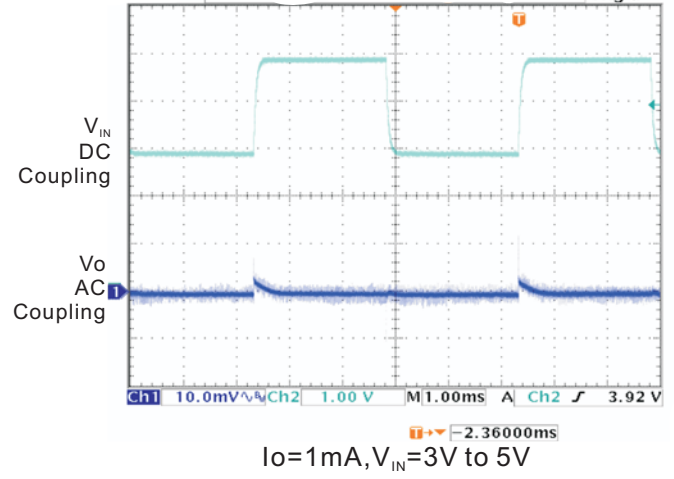

9. Power Supply Ripple Rejection

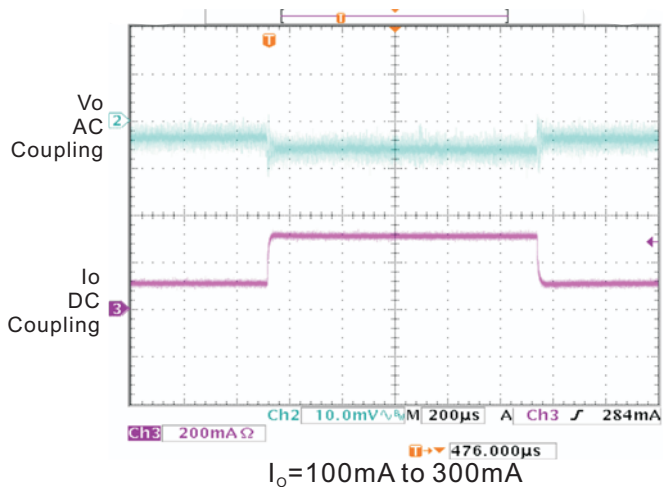
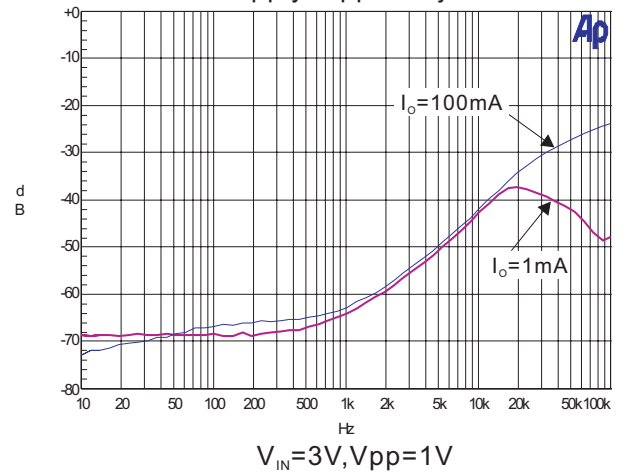



Application Information

Capacitor Selection and Regulator Stability

Similar to any low dropout regulator, the external capacitors used with the PAM3103 must be carefully selected for regulator stability and performance.

A capacitor C_{IN} of more than $1\mu F$ can be employed in the input pin, while there is no upper limit for the capacitance of C_{IN} . Please note that the distance between C_{IN} and the input pin of the PAM3103 should not exceed 0.5 inch. Ceramic capacitors are suitable for the PAM3103. Capacitors with larger values and lower ESR (equivalent series resistance) provide better PSRR and line-transient response.

The PAM3103 is designed specifically to work with low ESR ceramic output capacitors in order to save space and improve performance. Using an output ceramic capacitor whose value is $>2.2\mu F$ with $ESR > 5m\Omega$ ensures stability.

ADJ Output Voltage Programming

The output voltage of the PAM3103 adjustable regulator is programmed by using an external resistor divider as shown in Figure 1. The output voltage is calculated as below:

$$V_o = V_{REF}(1 + R1/R2)$$

Resistor R1 and R2 should be chosen for approximately $7\mu A$ divider current. Lower value resistors can be used but offer no advantage and waste more power. Higher value should be avoided as leakage current at ADJ pin increase the output voltage error. C_c is unnecessary when R1 or R2 $< 20k\Omega$. The recommended design procedure is to choose $R2 = 169k\Omega$ to set the divider current at $7\mu A$ and then calculate R1 as below:

$$R1 = (V_o/V_{REF} - 1)R2$$

Load Transient Considerations

Curve 7 of the PAM3103 load-transient response on page 5 shows two components of the output response: a DC shift from the output impedance due to the load current change and transient response. The DC shift is quite small due to excellent load regulation of the PAM3103. The transient spike, resulting from a step change in the load current from $1mA$ to $300mA$, is $20mV$. The ESR of the output capacitor is critical to the transient spike. A larger capacitance along with smaller ESR results in a smaller spike.

Shutdown Input Operation

The PAM3103 can be shut down by pulling the EN input low, and turned on by tying the EN input to VIN or leaving the EN input floating.

Internal P-Channel Pass Transistor

The PAM3103 features a 0.75Ω P-Channel MOSFET device as a pass transistor. The P-MOS pass transistor enables the PAM3103 to consume only $65\mu A$ of ground current during low dropout, light-load, or heavy-load operation. This feature increases the battery operation life time.

Input-Output (Dropout) Voltage

A regulator's minimum input-output voltage differential (or dropout voltage) determines the lowest usable supply voltage. The PAM3103 has a typical $300mV$ dropout voltage. In battery-powered systems, this will determine the useful end-of-life battery voltage.

Current Limit and Short Circuit Protection

The PAM3103 features a current limit, which monitors and controls the gate voltage of the pass transistor. The output current can be limited to $400mA$ by regulating the gate voltage. The PAM3103 also has a built-in short circuit current limit.



Thermal considerations

Thermal protection limits power dissipation in the PAM3103. When the junction temperature exceeds 150°C, the OTP (Over Temperature Protection) starts the thermal shutdown and turns the pass transistor off. The pass transistor resumes operation after the junction temperature drops below 120°C.

For continuous operation, the junction temperature should be maintained below 125°C. The power dissipation is defined as below:

$$P_D = (V_{IN} - V_{OUT}) * I_O + V_{IN} * I_{GND}$$

The maximum power dissipation depends on the thermal resistance of IC package, PCB layout, the rate of surrounding airflow and temperature difference between junction and ambient. The maximum power dissipation can be calculated by the following formula:

$$P_{D(MAX)} = (T_{J(MAX)} - T_A) / \theta_{JA}$$

Where $T_{J(MAX)}$ is the maximum allowable junction temperature 125°C, T_A is the ambient temperature and θ_{JA} is the thermal resistance from the junction to the ambient.

For example, as θ_{JA} is 250°C/W for the SOT-23

package based on the standard JEDEC 51-3 for a single-layer thermal test board, the maximum power dissipation at $T_A=25^\circ\text{C}$ can be calculated by following formula:

$$P_{D(MAX)} = (125^\circ\text{C} - 25^\circ\text{C}) / 250 = 0.4\text{W}$$

It is also useful to calculate the junction temperature of the PAM3103 under a set of specific conditions. Suppose the input voltage $V_{IN}=3.3\text{V}$, the output current $I_O=300\text{mA}$ and the case temperature $T_A=40^\circ\text{C}$ measured by a thermal couple during operation, the power dissipation is defined as:

$$P_D = (3.3\text{V} - 2.8\text{V}) * 300\text{mA} + 3.3\text{V} * 70\mu\text{A} \cong 150\text{mW}$$

And the junction temperature T_J can be calculated as follows:

$$\begin{aligned} T_J &= T_A + P_D * \theta_{JA} \\ T_J &= 40^\circ\text{C} + 0.15\text{W} * 250^\circ\text{C}/\text{W} \\ &= 40^\circ\text{C} + 37.5^\circ\text{C} \\ &= 77.5^\circ\text{C} < T_{J(MAX)} = 125^\circ\text{C} \end{aligned}$$

For this application, T_J is lower than the absolute maximum operating junction temperature 125°C, so it is safe to use the PAM3103 in this configuration.



Ordering Information

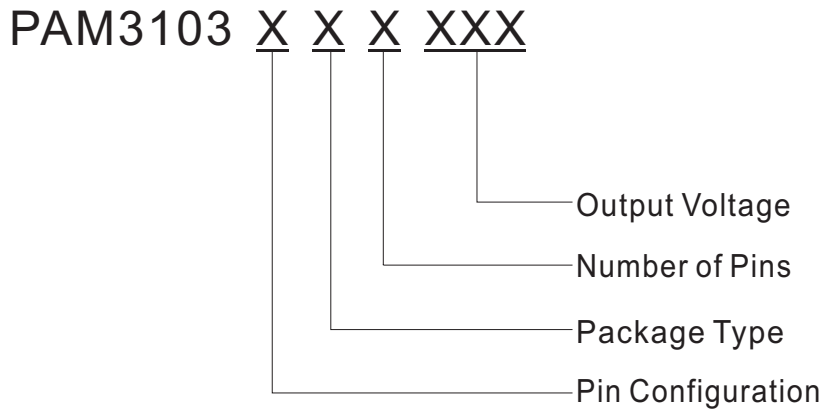

Pin Configuration	Package Type	Number of Pins	Output Voltage
A Type 1. VIN 2. GND 3. EN 4. ADJ 5. VOUT	A: SOT-23 U: SC70	B: 5	ADJ

Part Number	Output Voltage	Marking	Package Type	Standard Package
PAM3103AABADJ	ADJ	ACAYW	SOT23-5	3,000Units/Tape&Reel
PAM3103AUBADJ	ADJ	ACAYW	SC70-5	3,000Units/Tape&Reel

Outline Dimension

SOT23-5

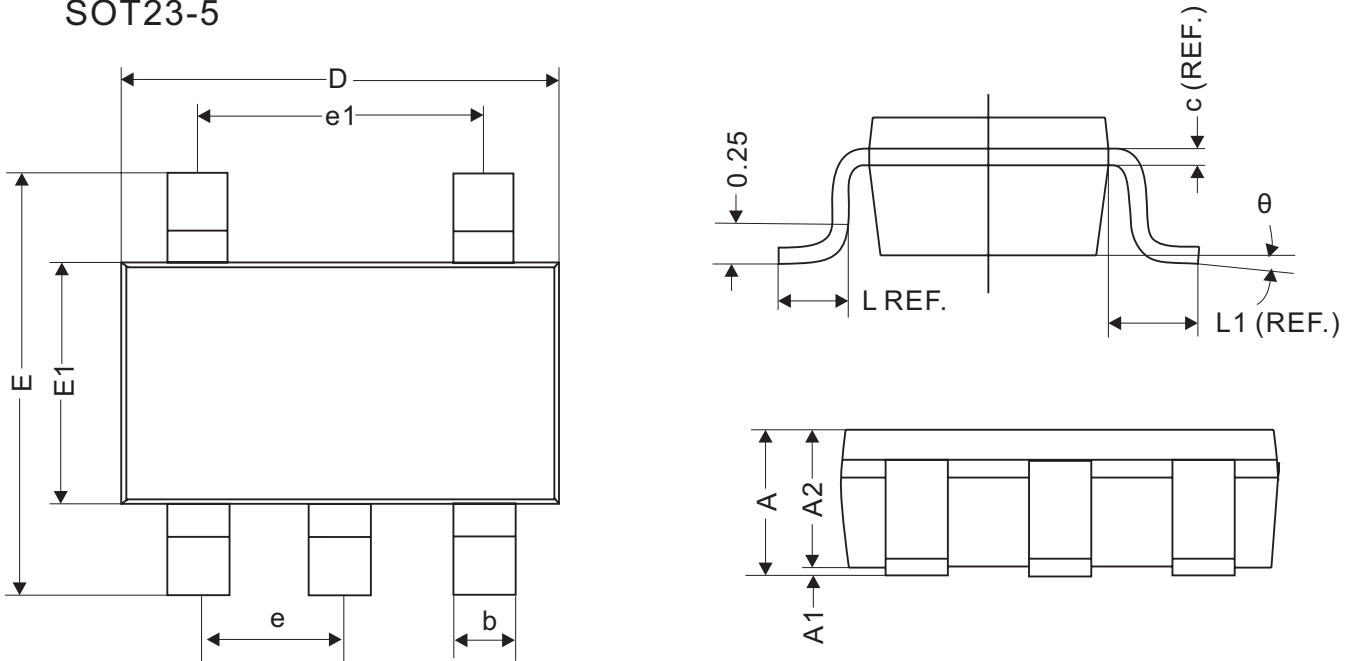

REF.	Millimeter	
	Min	Max
A	1.10MAX	
A1	0	0.10
A2	0.70	1
c	0.12REF.	
D	2.70	3.10
E	2.60	3.00
E1	1.40	1.80
L	0.45REF.	
L1	0.60REF.	
θ	0°	10°
b	0.30	0.50
e	0.95REF.	
e1	1.90REF.	

Outline Dimension

SC70-5

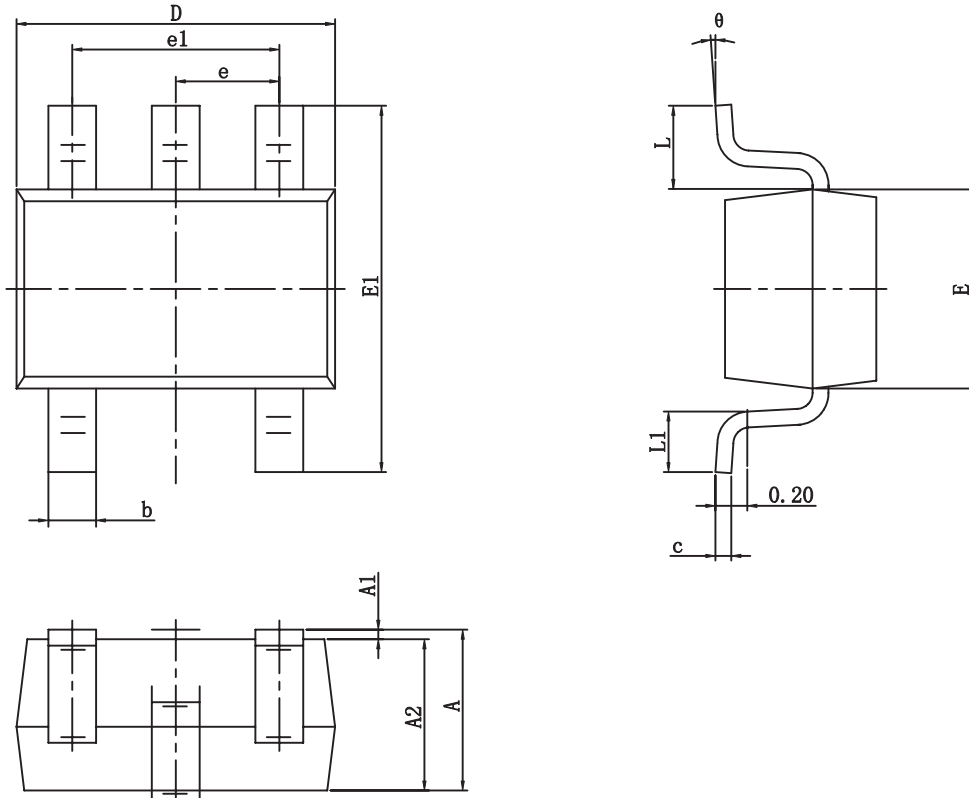

Symbol	Dimensions In Millimeters		Dimensions In Inches	
	Min	Max	Min	Max
A	0.900	1.100	0.035	0.043
A1	0.000	0.100	0.000	0.004
A2	0.900	1.000	0.035	0.039
b	0.150	0.350	0.006	0.014
c	0.080	0.150	0.003	0.006
D	2.000	2.200	0.079	0.087
E	1.150	1.350	0.045	0.053
E1	2.150	2.450	0.085	0.096
e	0.650 TYP		0.026 TYP	
e1	1.200	1.400	0.047	0.055
L	0.525 REF		0.021 REF	
L1	0.260	0.460	0.010	0.018
θ	0	8	0	8