

Features

- High Efficiency 92%
- Up to 350mA Constant Source Current
- Low Quiescent Current: Typ. 65 μ A
- 0.5 μ A Shutdown Current
- Short Circuit Protection
- Open Load LED Protection
- Thermal Protection
- Space Saving Package SOT23-5
- Pb-Free Package

General Description

The PAM2800 is a high power white LED driver with 350mA constant rated source current. It features high efficiency and low quiescent current, making it ideal for battery powered applications.

Applications

- High Power White LED Driver

Typical Application Circuit

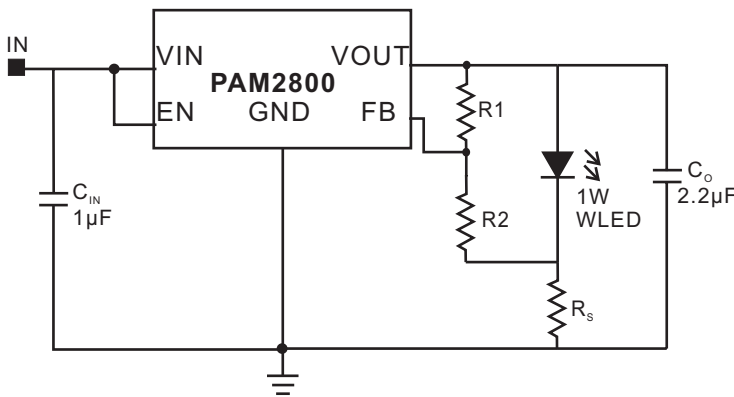
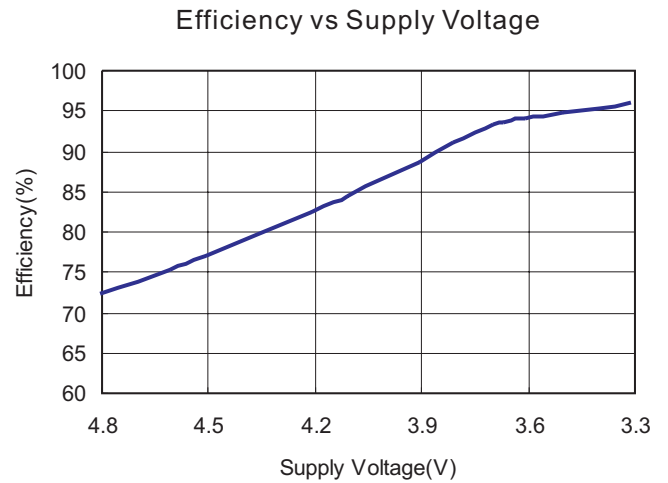
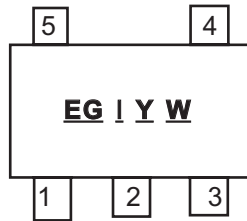

Figure 1



Pin Configuration & Marking Information

Top View
SOT23-5



EG: Product Code of PAM2800
I: Current Code
Y: Year
W: Week

Pin Number	Name	Function
1	VIN	Input
2	GND	Ground
3	EN	Chip Enable (Active High)
4	FB	Feedback
5	VOUT	Output



Absolute Maximum Ratings

These are stress ratings only and functional operation is not implied. Exposure to absolute maximum ratings for prolonged time periods may affect device reliability. All voltages are with respect to ground.

Input Voltage.....6.0V	Lead Soldering Temperature (5sec).....300°C
Output Current.....350mA	Storage Temperature.....-65°C to 150°C
Output Pin Voltage.....GND -0.3to $V_{IN}+0.3V$	

Recommended Operating Conditions

Max. Supply Voltage5.5V	Operation Temperature.....-40°C to 85°C
Junction Temperature.....-40°C to 125°C	

Thermal Information

Parameter	Symbol	Package	Maximum	Unit
Thermal Resistance (Junction to Case)	θ_{JC}	SOT23-5	130	°C/W
Thermal Resistance (Junction to Ambient)	θ_{JA}	SOT23-5	250	
Internal Power Dissipation	P_D	SOT23-5	400	mW

Electrical Characteristic

$T_A=25^\circ\text{C}, V_{IN}=3.7\text{V}, C_{IN}=1\mu\text{F}, C_O=2.2\mu\text{F}$, unless otherwise noted.

Parameter	Symbol	Test Conditions	Min	Typ	Max	Unit
Input Voltage	V_{IN}				5.5	V
Output Current	I_O		300			mA
Quiescent Current	I_Q	No Load		65	90	μA
Efficiency			90	92		%
Over Temperature Shutdown	OTS	$I_O=1\text{mA}$		150		°C
Over Temperature Hysteresis	OTH	$I_O=1\text{mA}$		30		°C

Typical Performance Characteristics

$T_A=25^{\circ}\text{C}, C_{IN}=1\mu\text{F}, C_O=2.2\mu\text{F}, R_1=62\text{k}\Omega, R_2=33\text{k}\Omega, R_S=0.22\Omega.$

Efficiency vs Supply Voltage

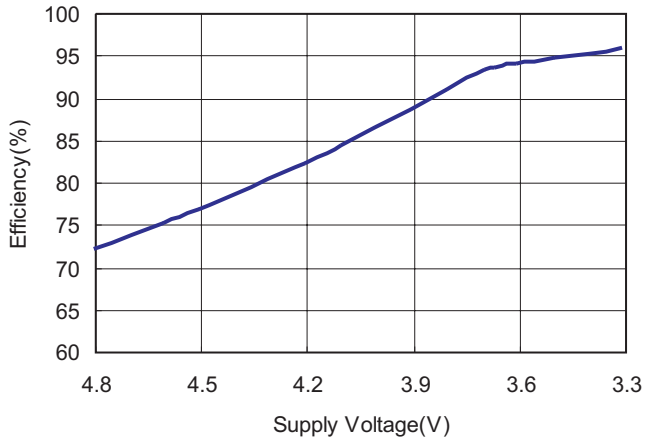

Output Current vs Supply Voltage

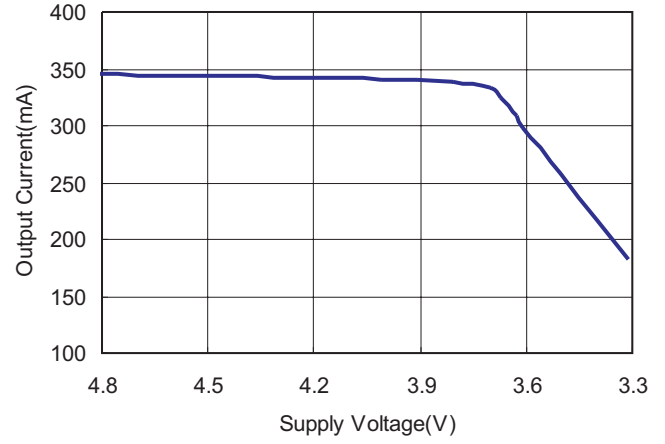

Application Information

In the typical application (see Figure 1), the LED current will come to constant current level little by little after the device is powered. A 62KΩ resistor is recommended for R1, and the value for R2 should be adjusted around 33KΩ due to LED forward voltage variation from lot-to-lot or brand-to-brand.

Power Dissipation and Thermal Consideration

Thermal protection limits power dissipation in the PAM2800. When the operation junction temperature exceeds 150°C, the OTP (Over Temperature Protection) starts the thermal shutdown and turns the pass transistor off. The pass transistor resumes operation after the junction temperature drops below 120°C.

For continuous operation, the junction temperature should be maintained below 125°C. The power dissipation is defined as:

$$P_D = (V_{IN} - V_{OUT}) * I_O + V_{IN} * I_{GND}$$

The maximum power dissipation depends on the thermal resistance of IC package, PCB layout, the rate of surrounding airflow and temperature difference between junction and ambient. The

maximum power dissipation can be calculated by the following formula:

$$P_{D(MAX)} = (T_{J(MAX)} - T_A) / \theta_{JA}$$

Where $T_{J(MAX)}$ is the maximum operation junction temperature 125°C. T_A is the ambient temperature, and θ_{JA} is the thermal resistance from the junction to the ambient.

For example, as θ_{JA} is 250°C/W for SOT-23, based on the standard JEDEC 51-3 for a single-layer thermal test board, the maximum power dissipation for SOT-23 package at $T_A=25^\circ\text{C}$ can be calculated by following formula:

$$P_{D(MAX)} = (125^\circ\text{C} - 25^\circ\text{C}) / 250 = 0.4\text{W}$$

To calculate the junction temperature of the PAM2800 SOT-23 package, if we use input voltage $V_{IN}=4\text{V}$ at an output current $I_O=300\text{mA}$ and the case temperature $T_A=40^\circ\text{C}$ measured by the thermal couple while operating, the power dissipation is defined as:

$$P_D = (4\text{V} - 2.8\text{V}) * 300\text{mA} + 4\text{V} * 70\mu\text{A} \approx 360\text{mW}$$

Ordering Information

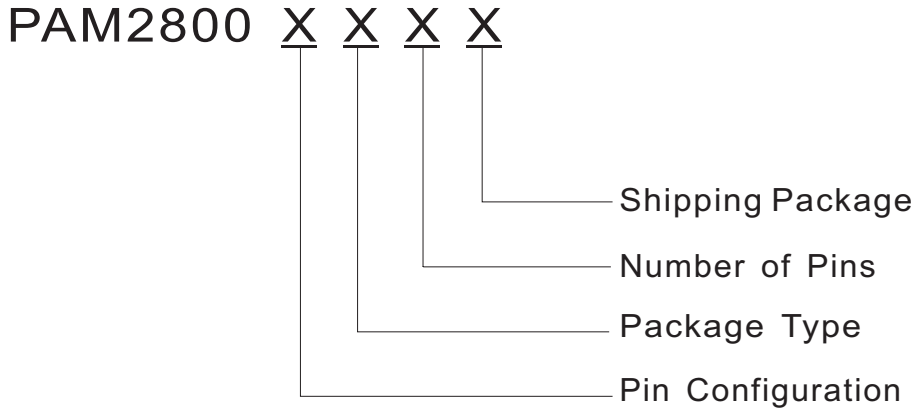

Pin Configuration	Package Type	Number of Pins	Shipping Package
A Type 1. VIN 2. GND 3. EN 4. FB 5. VOUT	A : SOT-23	B: 5	R: Tape & Reel

Part Number	Output Current	Marking	Package Type	MOQ
PAM2800AABR	350mA	EGAYW	SOT23-5	3,000 Units/Tape&Reel

Outline Dimension

SOT23-5

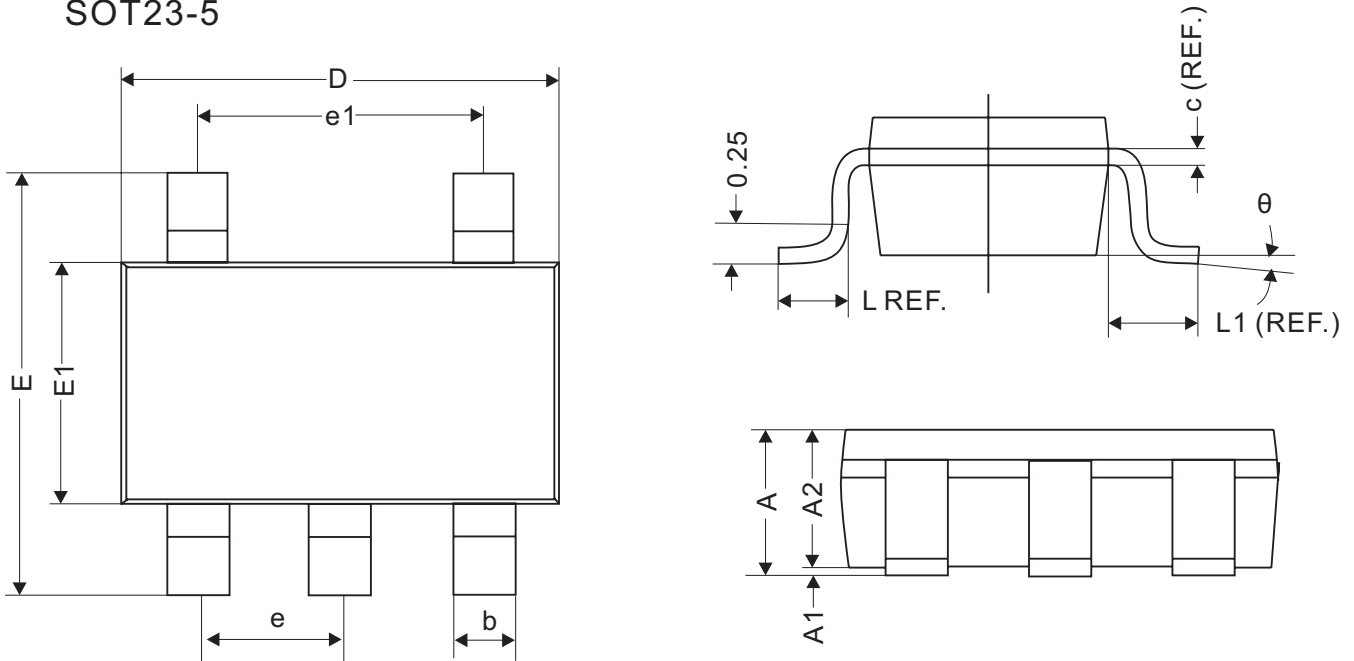

REF.	Millimeter	
	Min	Max
A	1.10MAX	
A1	0	0.10
A2	0.70	1
c	0.12REF.	
D	2.70	3.10
E	2.60	3.00
E1	1.40	1.80
L	0.45REF.	
L1	0.60REF.	
θ	0°	10°
b	0.30	0.50
e	0.95REF.	
e1	1.90REF.	