

Features

- Output Current: Up to 3A
- Output Voltage: 0.6V to V_{IN}
- Input Voltage: 2.7 to 5.5V
- Efficiency up to 95%
- 42 μ A (Typ) No Load Quiescent Current
- Shutdown Current: <1 μ A
- 100% Duty Cycle Operation
- 1.5MHz Switching Frequency
- Internal Soft Start
- No external Compensation Required
- Current Limit Protection
- Thermal Shutdown
- QFN3x3 16-Pin and SOP-8(EP) Package

Applications

- 5V or 3.3V Point of Load Conversion
- Telecom/Networking Equipment
- Set Top Boxes
- Storage Equipment
- Video Cards
- DDR Power Supply

Description

The PAM2307 is a 3A step-down DC-DC converter. At heavy load, the constant-frequency PWM control performs excellent stability and transient response. No external compensation components are required.

The PAM2307 supports a range of input voltages from 2.7V to 5.5V, allowing the use of a single Li+/Li-polymer cell, multiple Alkaline/NiMH cell, and other standard power sources. The output voltage is adjustable from 0.6V to the input voltage. The PAM2307 employs internal power switch and synchronous rectifier to minimize external part count and realize high efficiency. During shutdown, the input is disconnected from the output and the shutdown current is less than 1 μ A. Other key features include over-temperature and short circuit protection, and under-voltage lockout to prevent deep battery discharge.

The PAM2307 delivers 3A maximum output current while consuming only 42 μ A of no-load quiescent current. Ultra-low RDS(ON) integrated MOSFETs and 100% duty cycle operation make the PAM2307 an ideal choice for high output voltage, high current applications which require a low dropout threshold.

The PAM2307 is available in QFN3x3 16-Pin and PSOP8 package.

Typical Application

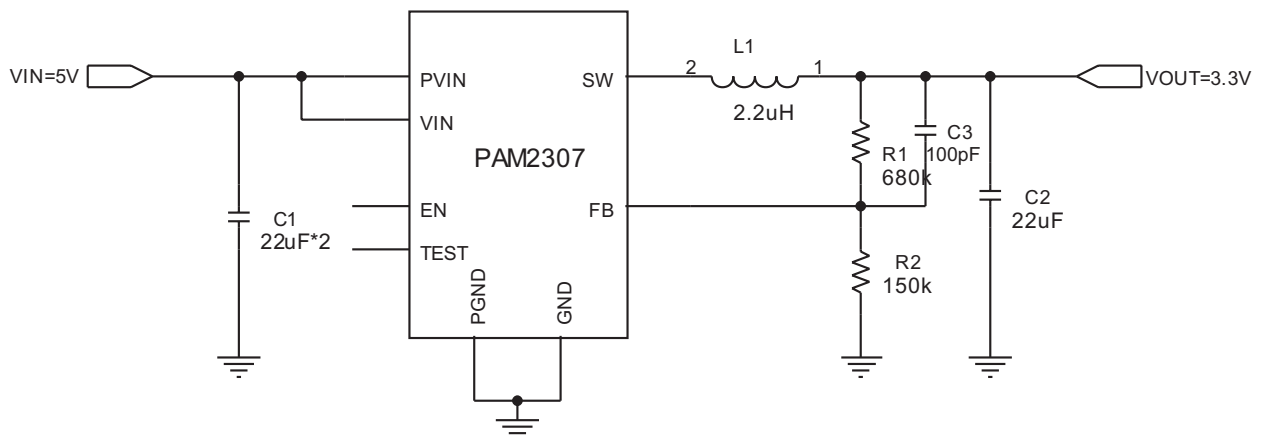

$$V_o = 0.6 \times \left(1 + \frac{R1}{R2} \right)$$

Block Diagram

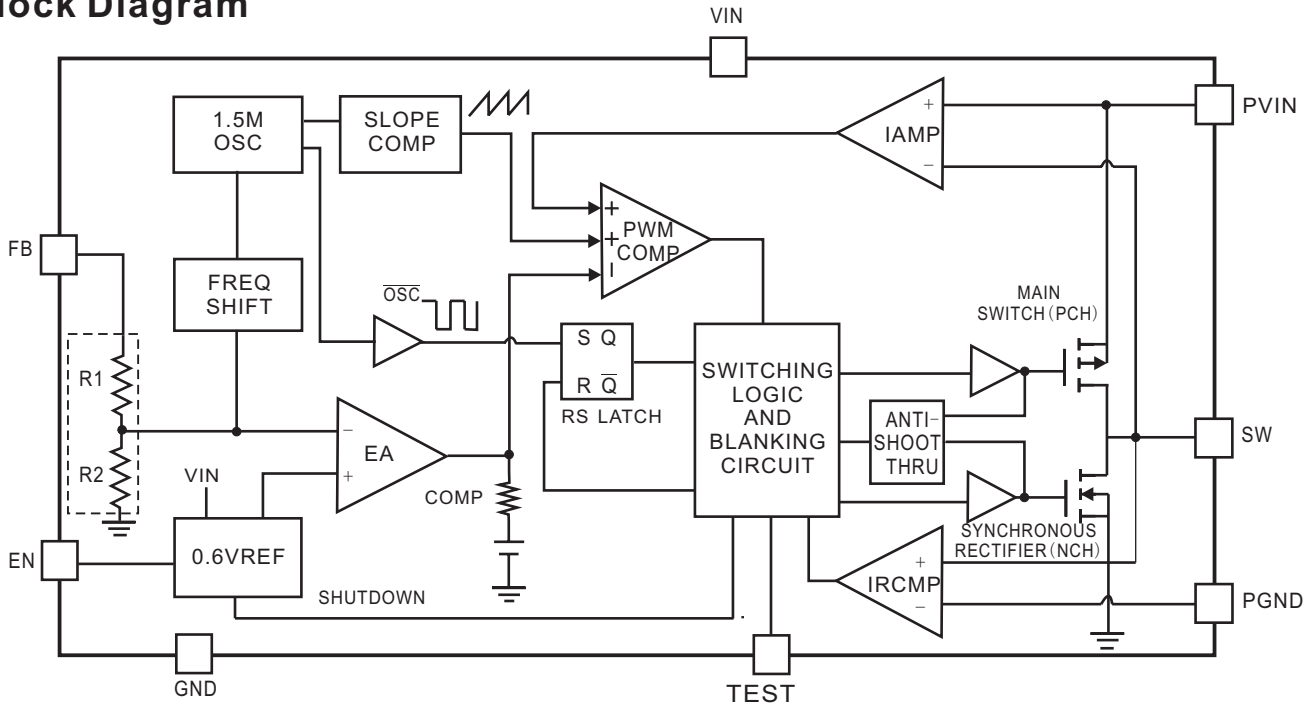

Pin Configuration & Marking Information

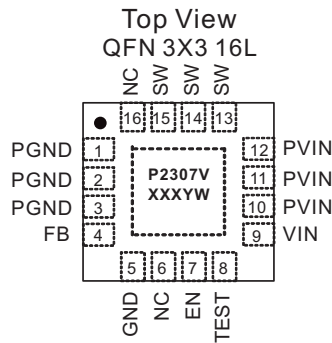

V: Output Voltage
 Y: Year
 W: Week
 X: Internal Code

Pin Description

Name	Pin Number	Function
PGND	1 - 3	Main power ground pin
FB	4	Feedback voltage to internal error amplifier, the threshold voltage is 0.6V.
GND	5	Signal ground for small signal components.
NC	6, 16	No connection
EN	7	Enable control input. Force this pin voltage above 1.5V, enables the chip, and below 0.3V shuts down the device.
TEST	8	Test Mode(no connect or to Ground)
VIN	9	Bias supply. Chip main power supply pin
PVIN	10 -12	Input supply for power stage. Must be closely decoupled to PGND
SW	13 -15	The drains of the internal main and synchronous power MOSFET.

Pin Configuration & Marking Information

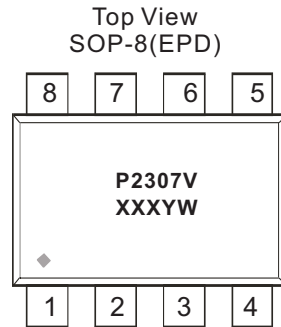

V: Output Voltage
Y: Year
W: Week
X: Internal Code

Pin Description

Name	Pin Number	Function
SW	1	The drains of the internal main and synchronous power MOSFET.
PGND	2	Main power ground pin
FB	3	Feedback voltage to internal error amplifier, the threshold voltage is 0.6V.
GND	4	Signal ground for small signal components.
EN	5	Enable control input. Force this pin voltage above 1.5V, enables the chip, and below 0.3V shuts down the device.
TEST	6	Test Mode(no connect or to Ground)
VIN	7	Bias supply. Chip main power supply pin
PVIN	8	Input supply for power stage. Must be closely decoupled to PGND

Absolute Maximum Ratings

These are stress ratings only and functional operation is not implied. Exposure to absolute maximum ratings for prolonged time periods may affect device reliability. All voltages are with respect to ground.

Input Voltage PV_{IN}, V_{IN}	6V	Maximum Junction Temperature.....	150°C
SW Pin Voltage.....	-0.3V to $(PV_{IN}+0.3V)$	Storage Temperature Range.....	-65°C to 150°C
FB Pin Voltage.....	-0.3V to $(V_{IN}+0.3V)$	Soldering Temperature.....	300°C, 5sec
EN Pin Voltage.....	-0.3V to -6V		

Recommended Operating Conditions

Supply Voltage.....	2.5V to 5.5V	Junction Temperature Range.....	-40°C to 125°C
		Ambient Temperature Range.....	-40°C to 85°C

Thermal Information

Parameter	Symbol	Package	Maximum	Unit
Thermal Resistance (Junction to Ambient)	θ_{JA}	QFN 3x3-16	35	°C/W
		SOP-8(EP)	90	
Thermal Resistance (Junction to Case)	θ_{JC}	QFN 3x3-16	14	°C/W
		SOP-8(EP)	11	



PAM2307

3A Low Noise Step-Down DC-DC Converter

Electrical Characteristic

$T_A=25^{\circ}\text{C}$, $V_{in}=3.6\text{V}$, $V_o=1.8\text{V}$, $C_{in}=22*2\mu\text{F}$, $C_o=22\mu\text{F}$, $L=2.2\mu\text{H}$, unless otherwise noted.

PARAMETER	SYMBOL	Test Conditions	MIN	TYP	MAX	UNITS
Input Voltage Range	V_{IN}		2.5		5.5	V
Output Voltage Range	V_O		0.6		V_{IN}	V
UVLO Threshold	V_{UVLO}	V_{IN} Rising		2.4	2.5	V
		Hysteresis		240		mV
		V_{IN} Falling	1.8			V
Regulated Output Voltage Accuracy	V_O	$I_o = 0$ to 3A , $V_{IN}=2.5$ to 5.5V	-2		+2	%
Regulated Feedback Voltage	V_{FB}		0.588	0.6	0.612	V
FB Leakage Current	I_{FB}	$V_O=1\text{V}$			0.2	μA
Output Voltage Line Regulation	LNR	$V_{IN} = 2.5\text{V}$ to 5V		0.2		%/V
Output Voltage Load Regulation	LDR	$I_o=0\text{A}$ to 3A		0.5		%/A
Quiescent Current	I_Q	No load		42	90	μA
Shutdown Current	I_{SD}	$V_{EN} = 0\text{V}$			1	μA
Current Limit	I_{LIM}			3.5		A
Oscillator Frequency	f_{OSC}		1.2	1.5	1.8	MHz
Drain-Source On-State Resistance	$R_{DS(ON)}$	High Side		0.140		Ω
		Low Side		0.09		Ω
High Efficiency	η				95	%
Start up Time	t_S	From enable to output regulation			3	ms
EN Threshold High	V_{EH}		1.5			V
EN Threshold Low	V_{EL}				0.3	V
EN Leakage Current	I_{EN}	$V_{IN}=V_{EN} = 0\text{V}$	-1.0		1.0	μA
Over Temperature Protection	OTP			150		$^{\circ}\text{C}$
OTP Hysteresis	OTH			30		$^{\circ}\text{C}$



Typical Performance Characteristics

$T_A=25^{\circ}\text{C}$, $C_{IN}=22*2\mu\text{F}$, $C_o=22\mu\text{F}$ unless otherwise noted.

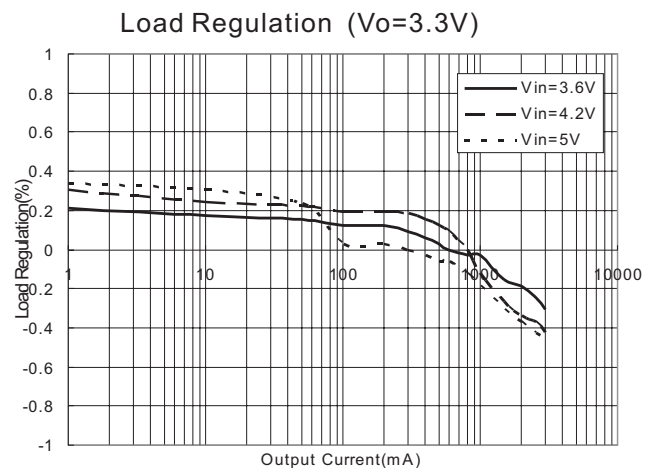
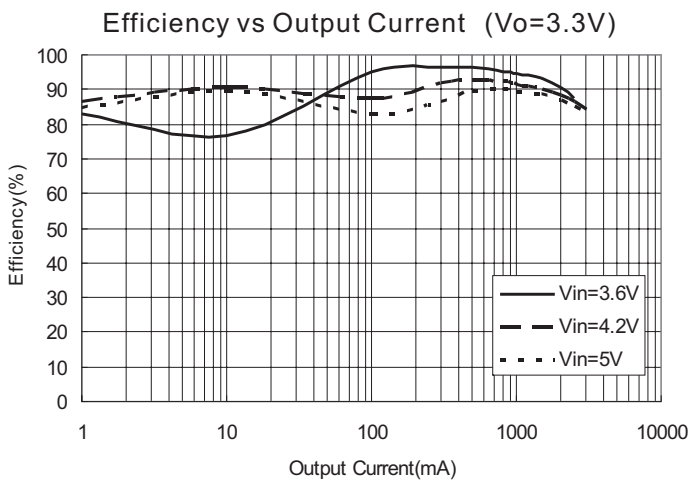
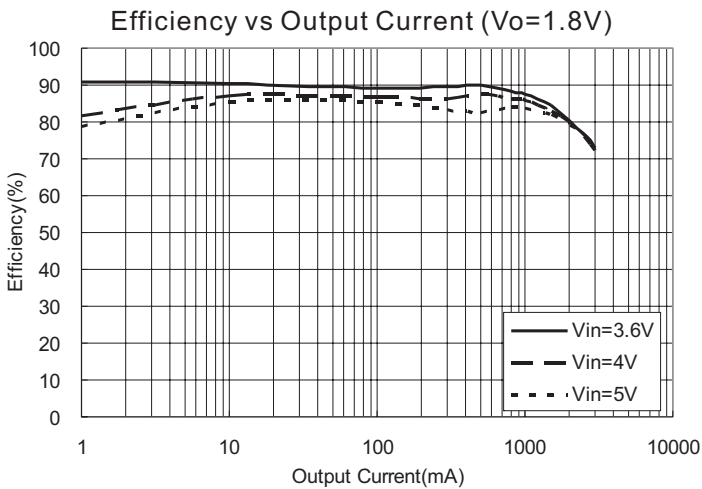
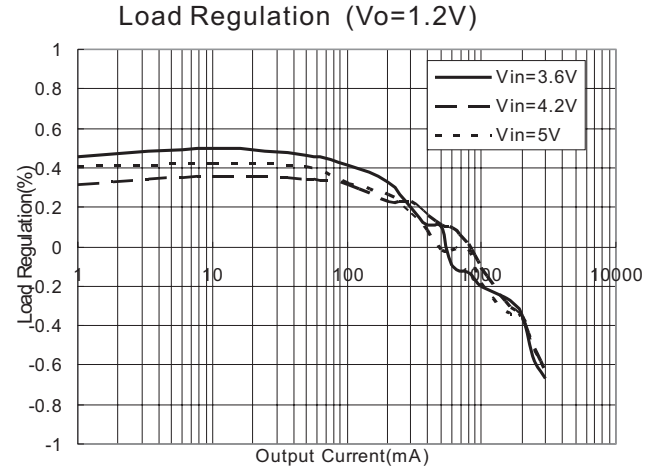
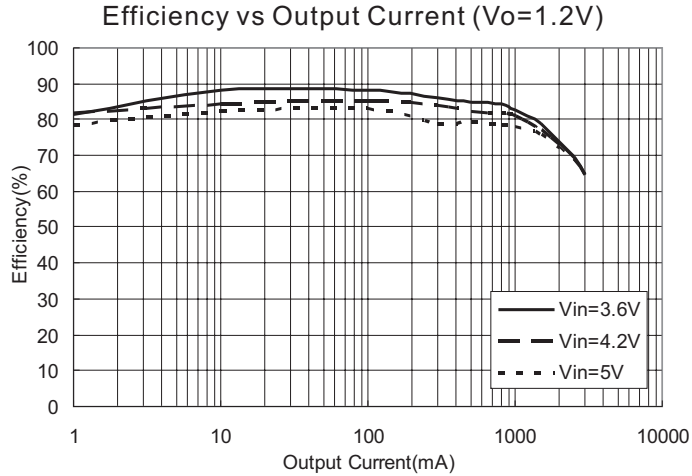

Typical Performance Characteristics

$T_A=25^\circ\text{C}$, $C_{IN}=22\mu\text{F}$, $C_O=22\mu\text{F}$ unless otherwise noted.

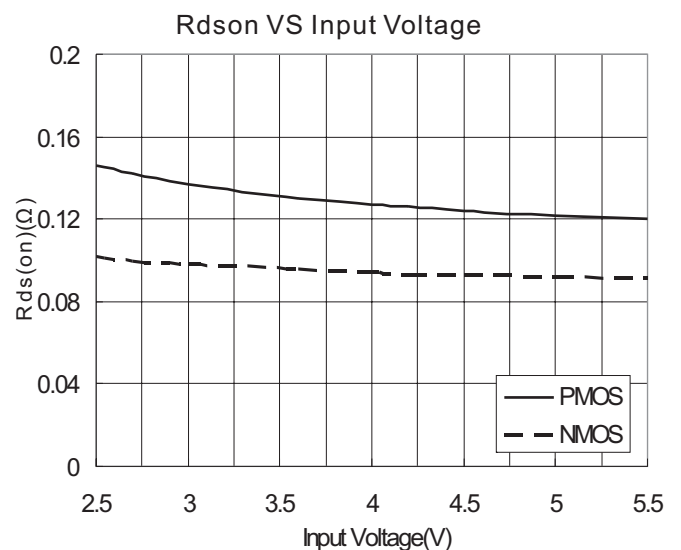
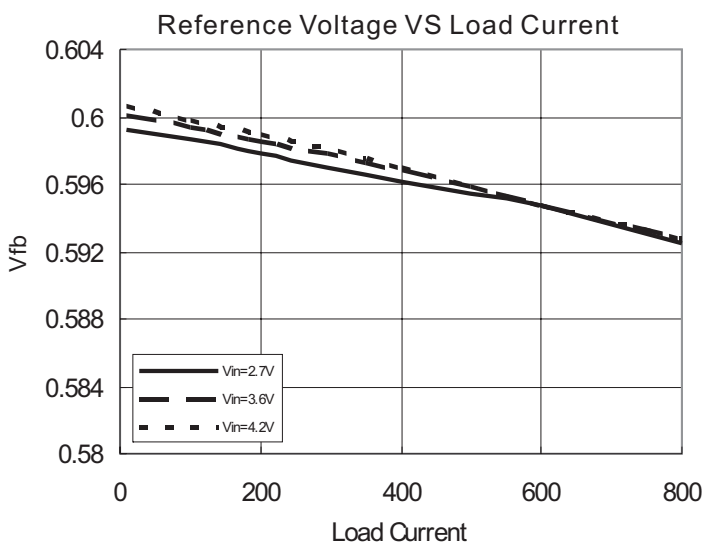
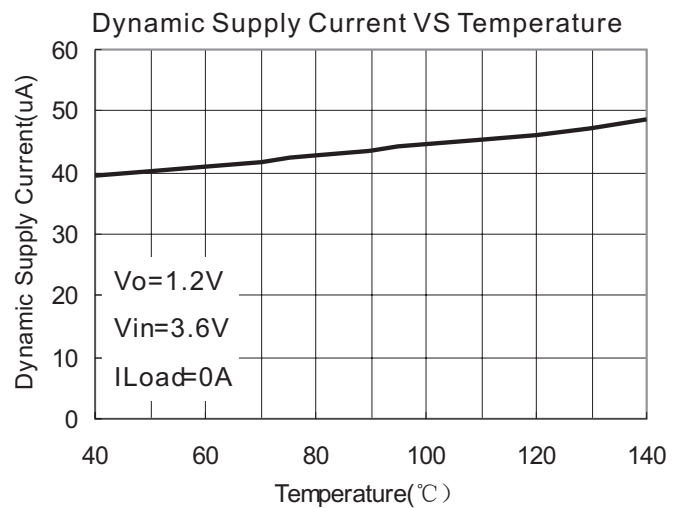
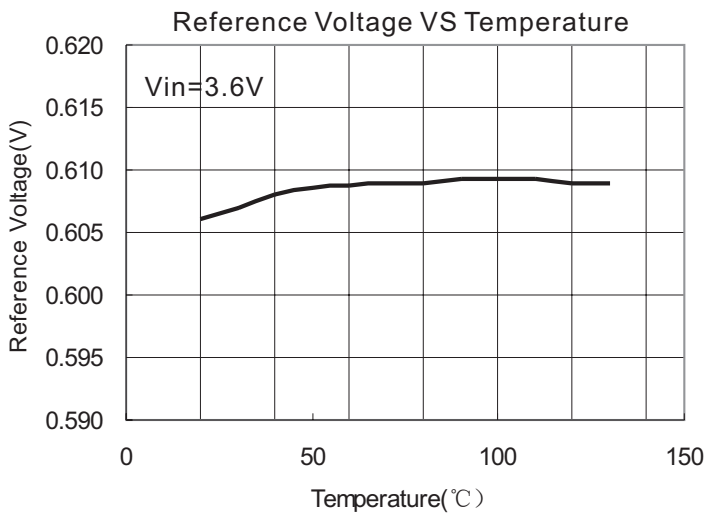
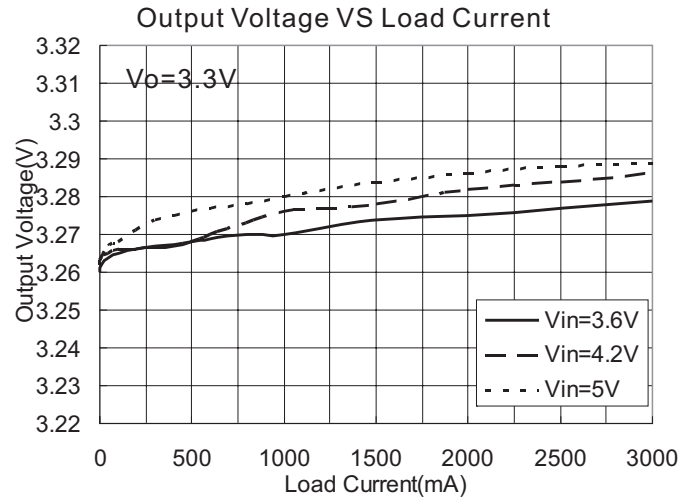
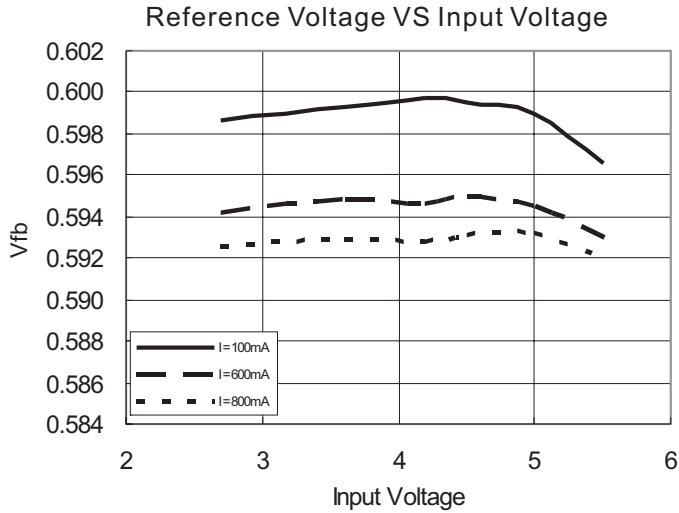

Typical Performance Characteristics

$T_A=25^\circ\text{C}$, $C_{IN}=22*2\mu\text{F}$, $C_o=22\mu\text{F}$ unless otherwise noted.

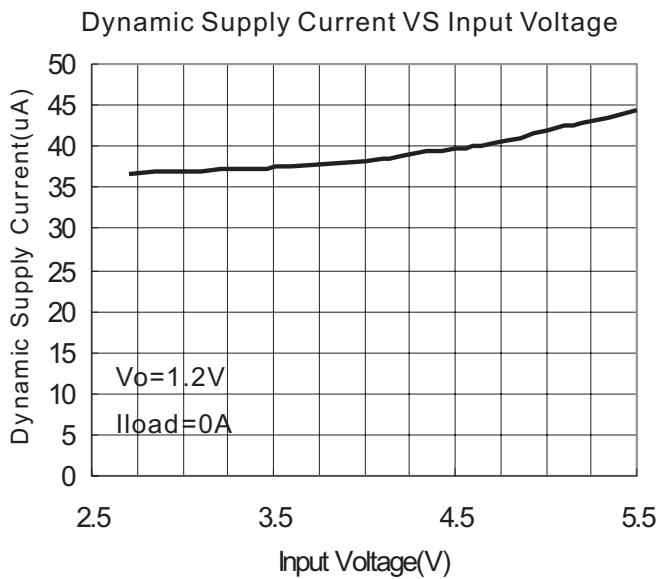
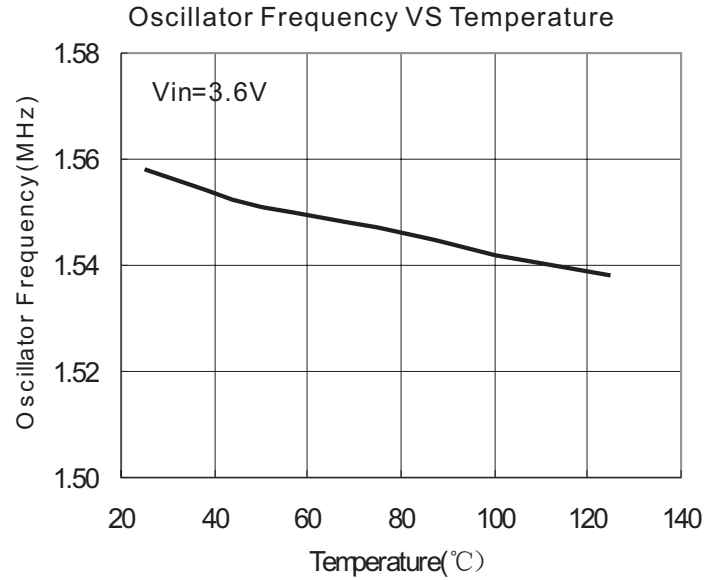
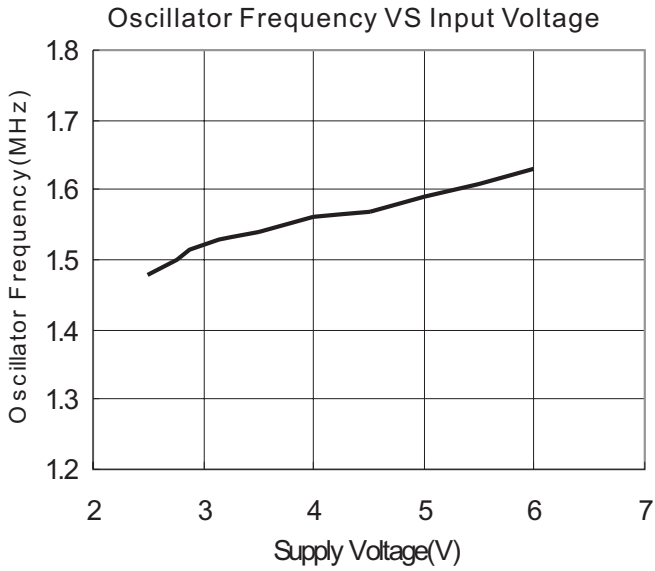

Typical Performance Characteristics

$T_A=25^\circ\text{C}$, $C_{IN}=22*2\mu\text{F}$, $C_O=22\mu\text{F}$ unless otherwise noted.

Load Transient
 $I_o=0\text{-}3\text{A}$, $V_o=1.2\text{V}$, $V_{in}=5\text{V}$

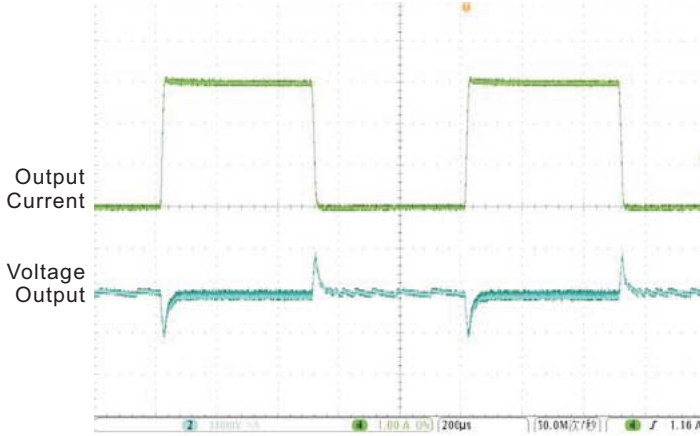

Load Transient
 $I_o=1\text{-}3\text{A}$, $V_o=1.2\text{V}$, $V_{in}=5\text{V}$

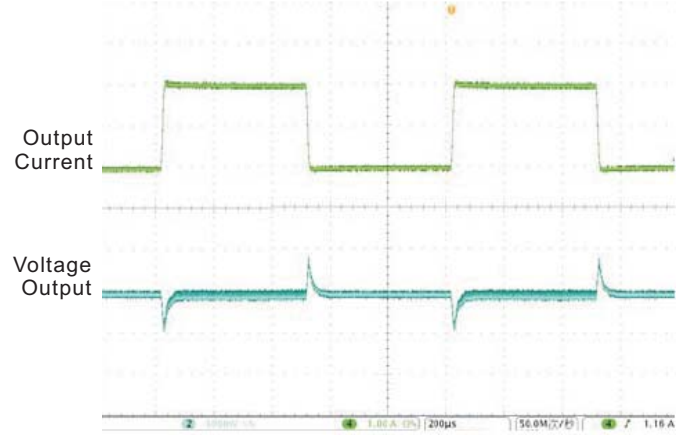

Load Transient
 $I_o=0\text{-}1\text{A}$, $V_o=1.2\text{V}$, $V_{in}=5\text{V}$

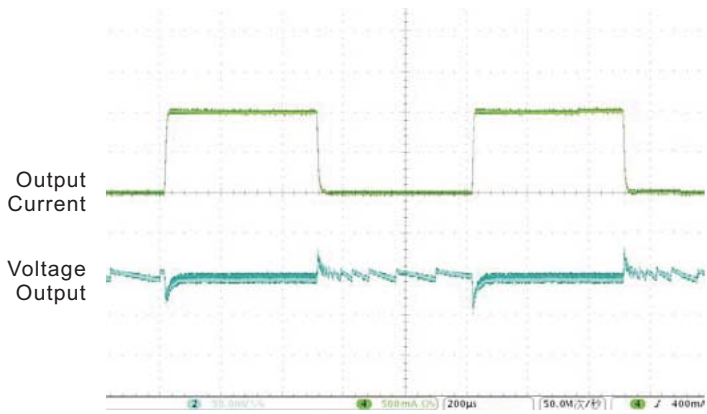

Load Transient
 $I_o=1\text{-}2\text{A}$, $V_o=3.3\text{V}$, $V_{in}=5\text{V}$

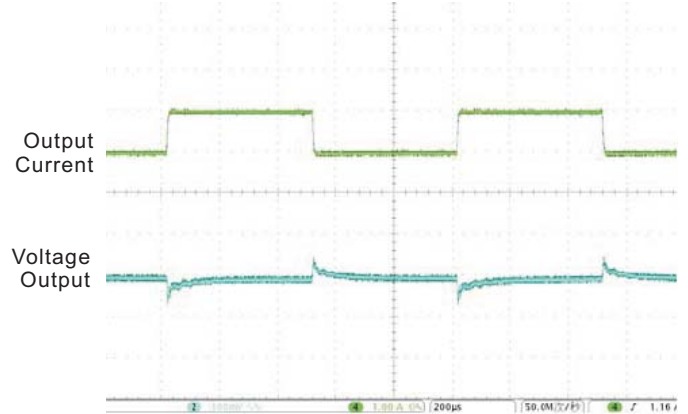

Start-up from Shutdown
 $V_o=1.2\text{V}$, $V_{in}=5\text{V}$, $I_o=2\text{A}$

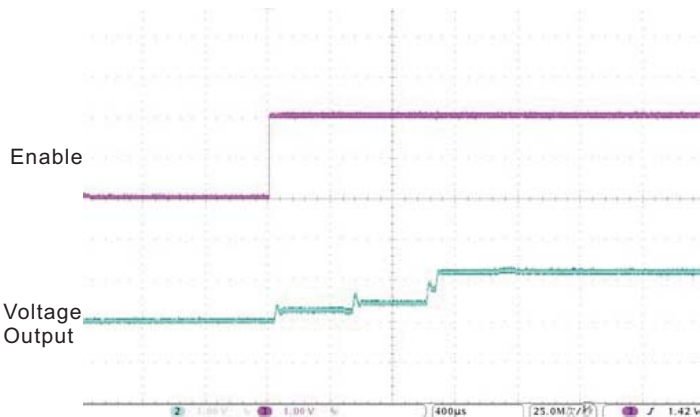

Start-up from Shutdown
 $V_o=1.2\text{V}$, $V_{in}=5\text{V}$, $I_o=3\text{A}$

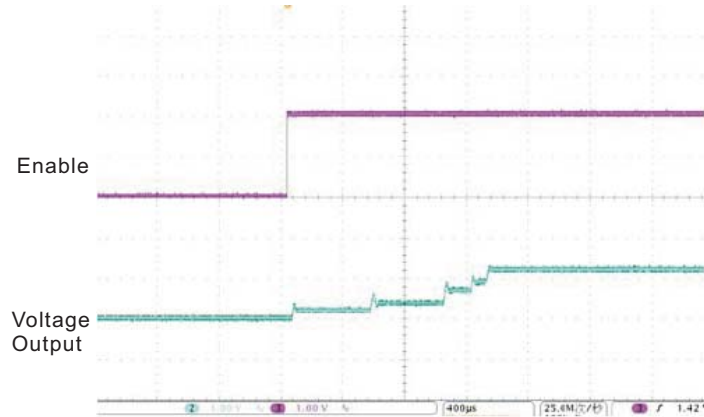

Application Information

The basic PAM2307 application circuit is shown in Page 1. External component selection is determined by the load requirement, selecting L first and then Cin and Cout.

Inductor Selection

For most applications, the value of the inductor will fall in the range of 1μH to 2.7μH. Its value is chosen based on the desired ripple current and efficiency. Large value inductors lower ripple current and small value inductors result in higher ripple currents. Higher Vin or Vout also increases the ripple current as shown in equation 3A reasonable starting point for setting ripple current is ΔIL = 1.2A (40% of 3A).

$$\Delta I_L = \frac{1}{(f)(L)} V_{OUT} \left(1 - \frac{V_{OUT}}{V_{IN}} \right) \quad (1)$$

The DC current rating of the inductor should be at least equal to the maximum load current plus half the ripple current to prevent core saturation. Thus, a 4.2A rated inductor should be enough for most applications (3A + 1.2A). For better efficiency, choose a low DC-resistance inductor.

Vo	1.2V	1.5V	1.8V	2.5V	3.3V
L	1.2μH	1.5μH	2.2μH	2.2μH	2.2μH

Cin and Cout Selection

In continuous mode, the source current of the top MOSFET is a square wave of duty cycle Vout/Vin. To prevent large voltage transients, a low ESR input capacitor sized for the maximum RMS current must be used. The maximum RMS capacitor current is given by:

$$C_{IN} \text{ required } I_{RMS} \cong I_{OMAX} \frac{[V_{OUT}(V_{IN} - V_{OUT})]^{1/2}}{V_{IN}}$$

This formula has a maximum at Vin = 2Vout, where IRMS = IOUT/2. This simple worst-case condition is commonly used for design because even significant deviations do not offer much relief. Note that the capacitor manufacturer's ripple current ratings are often based on 2000 hours of life. This makes it advisable to further derate the capacitor, or choose a capacitor rated at a higher temperature than required. Consult the manufacturer if there is any question.

The selection of Cout is driven by the required effective series resistance (ESR).

Typically, once the ESR requirement for Cout has been met, the RMS current rating generally far exceeds the I_{ripple}(P-P) requirement. The output ripple ΔVout is determined by:

$$\Delta V_{out} \approx \Delta I_L (ESR + 1/8fC_{out})$$

Where f = operating frequency, C_{out} = output capacitance and ΔIL = ripple current in the inductor. For a fixed output voltage, the output ripple is highest at maximum input voltage since ΔIL increases with input voltage.

Using Ceramic Input and Output Capacitors

Higher values, lower cost ceramic capacitors are now becoming available in smaller case sizes. Their high ripple current, high voltage rating and low ESR make them ideal for switching regulator applications. Using ceramic capacitors can achieve very low output ripple and small circuit size.

When choosing the input and output ceramic capacitors, choose the X5R or X7R dielectric formulations. These dielectrics have the best temperature and voltage characteristics of all the ceramics for a given value and size.

Thermal consideration

Thermal protection limits power dissipation in the PAM2307. When the junction temperature exceeds 150°C, the OTP (Over Temperature Protection) starts the thermal shutdown and turns the pass transistor off. The pass transistor resumes operation after the junction temperature drops below 120°C.

For continuous operation, the junction temperature should be maintained below 125°C. The power dissipation is defined as:

$$P_D = I_o^2 \frac{V_o R_{DS(on)H} + (V_{IN} - V_o) R_{DS(on)L}}{V_{IN}} + (t_{sw} F_{s} I_o + I_Q) V_{IN}$$

I_o is the step-down converter quiescent current. The term tsw is used to estimate the full load step-down converter switching losses.

For the condition where the step-down converter is in dropout at 100% duty cycle, the total device dissipation reduces to:

$$P_D = I_O^2 R_{DS(ON)} + I_Q V_{IN}$$

Since $R_{DS(ON)}$, quiescent current, and switching losses all vary with input voltage, the total losses should be investigated over the complete input voltage range. The maximum power dissipation depends on the thermal resistance of IC package, PCB layout, the rate of surrounding airflow and temperature difference between junction and ambient. The maximum power dissipation can be calculated by the following formula:

$$P_D = \frac{T_{J(MAX)} - T_A}{\theta_{JA}}$$

Where $T_{J(max)}$ is the maximum allowable junction temperature 125°C. T_A is the ambient temperature and θ_{JA} is the thermal resistance from the junction to the ambient. Based on the standard JEDEC for a two layers thermal test board, the thermal resistance θ_{JA} of QFN3X3 68°C/W and SOP-8(EP) 90°C/W respectively. The maximum power dissipation at $T_A = 25^\circ\text{C}$ can be calculated by following formula:

$$P_D = (125^\circ\text{C} - 25^\circ\text{C}) / 68^\circ\text{C/W} = 1.47\text{W (QFN3X3)}$$

$$P_D = (125^\circ\text{C} - 25^\circ\text{C}) / 90^\circ\text{C/W} = 1.11\text{W (SOP-8)}$$

Setting the Output Voltage

The internal reference is 0.6V (Typical). The output voltage is calculated as below:

The output voltage is given by Table 1.

$$V_o = 0.6 \times \left(1 + \frac{R1}{R2} \right)$$

Table 1: Resistor selection for output voltage setting

Vo	R1	R2
1.2V	100k	100k
1.5V	150k	100k
1.8V	200k	100k
2.5V	380k	120k
3.3V	540k	120k

100% Duty Cycle Operation

As the input voltage approaches the output voltage, the converter turns the P-channel transistor continuously on. In this mode the output voltage is equal to the input voltage minus the voltage drop across the P - channel transistor:

$$V_{OUT} = V_{IN} - I_{LOAD} (R_{dson} + R_L)$$

where R_{dson} = P-channel switch ON resistance, I_{LOAD} = Output current, R_L = Inductor DC resistance

UVLO and Soft-Start

The reference and the circuit remain reset until the VIN crosses its UVLO threshold.

The PAM2307 has an internal soft-start circuit that limits the in-rush current during start-up. This prevents possible voltage drops of the input voltage and eliminates the output voltage overshoot. The soft-start acts as a digital circuit to increase the switch current in several steps to the P-channel current limit (1500mA).

Short Circuit Protection

The switch peak current is limited cycle-by-cycle to a typical value of 1500mA. In the event of an output voltage short circuit, the device operates with a frequency of 400kHz and minimum duty cycle, therefore the average input current is typically 200mA.

Thermal Shutdown

When the die temperature exceeds 150°C, a reset occurs and the reset remains until the temperature decrease to 120°C, at which time the circuit can be restarted.



Ordering Information

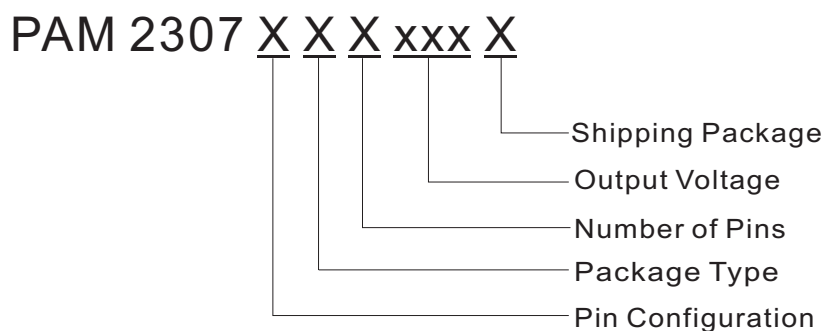

Pin Configuration	Package Type	Number of Pins	Output Voltage
A Type 16 pins	J: QFN 3x3	E: 16	ADJ: Adj
B Type 8 pins	E: SOP-8(EP)	C: 8	ADJ: Adj

Part Number	Output Voltage	Package Type	Shipping Package
PAM2307AJEADJR	ADJ	QFN3x3-16	3,000 Units/Tape & Reel
PAM2307BECADJR	ADJ	SOP-8(EP)	2,500 Units/Tape & Reel

Outline Dimensions

3x3 mm QFN 16

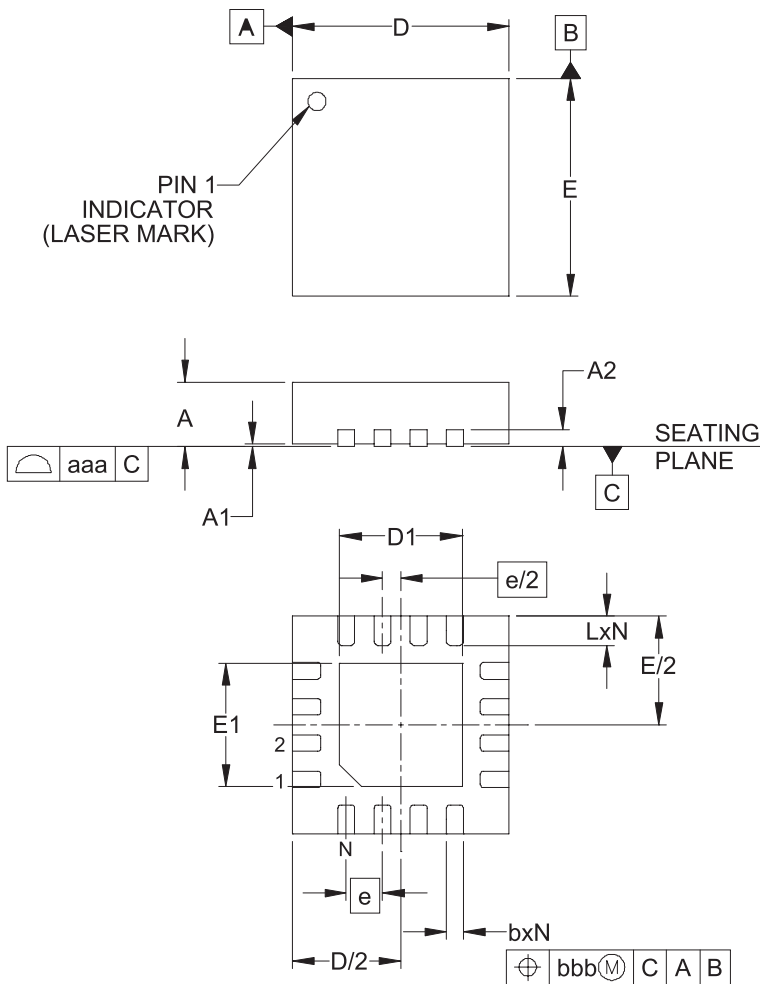

DIMENSIONS (Millimeters)			
	MIN	TYP	MAX
A	0.50	0.55	0.60
A1	0.00	0.02	0.05
A2	0.20		
b	0.18	0.25	0.30
D	2.90	3.00	3.10
D1	1.55	1.70	1.80
E	2.90	3.00	3.10
E1	1.55	1.70	1.80
e	0.50BSC		
L	0.30	0.40	0.50
N	16		
aaa	0.08		
bbb	0.10		

NOTES:

1. CONTROLLING DIMENSIONS ARE IN MILLIMETERS (ANGLES IN DEGREES).
2. COPLANARITY APPLIES TO THE EXPOSED PAD AS WELL AS THE TERMINALS.
3. DAP IS 1.90 x 1.90mm.

Outline Dimensions

SOP-8

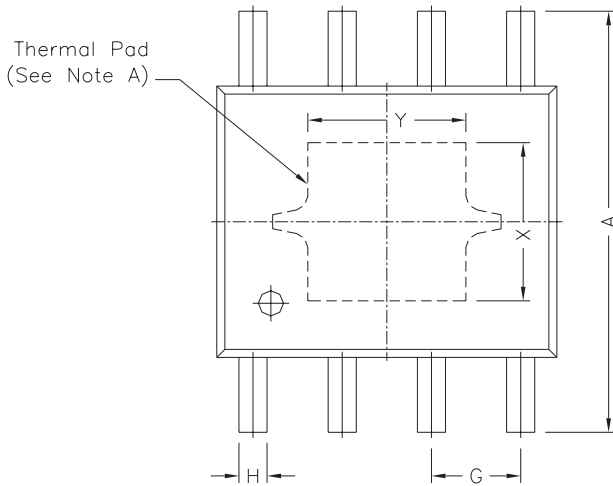

REF.	DIMENSIONS	
	Millimeters	
	Min.	Max.
A	5.80	6.20
B	4.80	5.00
C	3.80	4.00
D	0°	8°
E	0.40	0.90
F	0.19	0.25
M	0	0.15
H	0.35	0.49
L	1.35	1.75
G	1.27 TYP.	
Option1	X	2.28
	Y	2.28
Option2	X	2.41
	Y	3.30

